

Plenty



TWINRO - TWIN SCREW PUMP

Plenty Mirrlees Pumps

TWINRO

TWINRO - TWIN SCREW PUMP

FLOWS UP TO
1750 USgpm (50Hz)
1875 USgpm (60 Hz)

OPERATING PRESSURE
UP TO
350 PSI W40
200 PSI W80 to W375

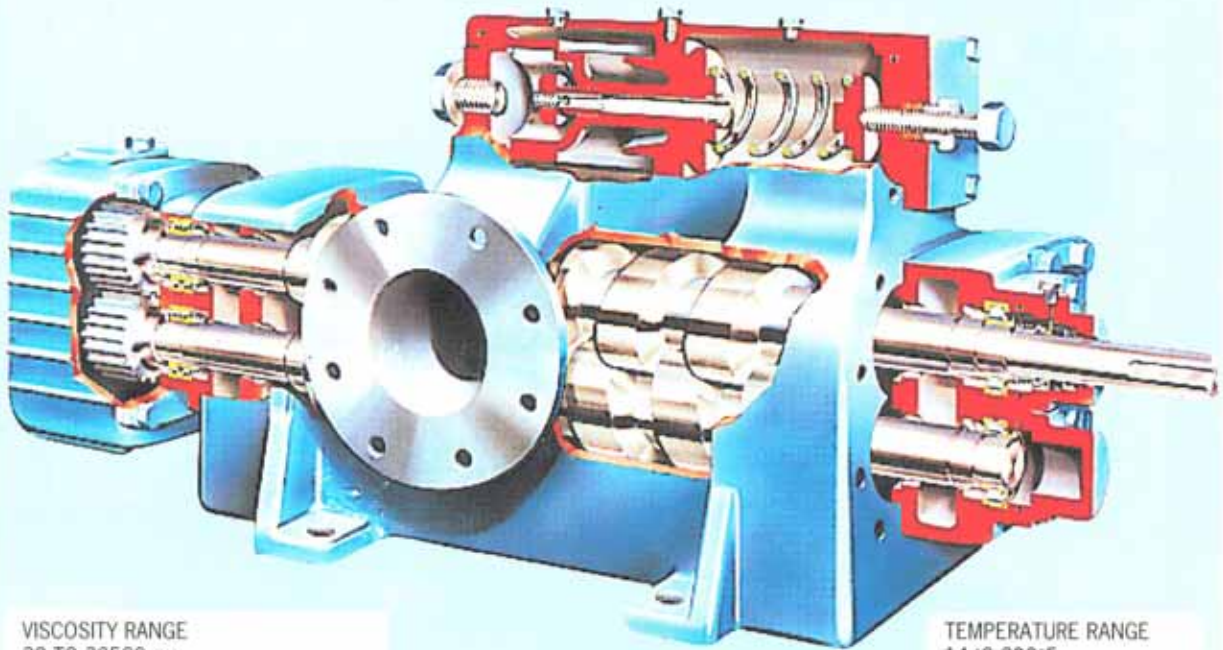

VISCOSITY RANGE
30 TO 32500 cSt
Higher viscosity can be accommodated
with special seals and reduced speed

TEMPERATURE RANGE
14 to 390°F
(-40°F with low temperature
steel construction)

TWINRO ("W" series) pumps from Plenty Mirrlees are positive displacement rotary twin screw pumps designed for bulk transfer of liquids.

The TWINRO series is available in five frame sizes with a selection of different pitch screwsets to match system flow requirements at 50Hz. or 60Hz. direct electric motor speeds. Pumps may also be driven at other speeds from diesel engines or other prime movers.

The material and design options available enable the pump to be offered for most bulk liquid transfer duties across many industries. In particular the pump is used extensively in bulk loading and unloading duties in the Oil, Marine, Power Generation and Chemical Industries.

Applications

Any bulk transfer of liquid - such as:

- Rail/Road car unloading/loading
- Tank to tank transfer
- Tank to process transfer
(and process to tank transfer)
- Ships bunkering
- Ships liquid cargo pumping
- Bilge and ballast pumping
- Distribution in liquid marketing terminals
- Pipeline and process flow requirements

Liquids Pumped

Pumps constructed from stock materials (iron and steel) are commonly used for:

- Lubricating oils
- Fuel Oils (residual and distillate)
- Petroleum liquids
- Bitumens/Asphalts
- Solvents
- Vegetable oils
- Glues, Varnish, Resins, Paints, Polymers

Custom built pumps - typically in stainless steels or bronze are used for applications with mild corrosion effect.

- Palm Oils
- Fatty Acids
- Water (fresh or sea)
- Some acids

DESIGN AND CONSTRUCTION

Designed around a cast body and cover shapes the TWINRO pump offers a low cost unit with minimum material requirements. The pumping element consists of two contra-rotating shafts from which right hand and left hand epicycloid screw shapes are accurately machined. The screwset conveys the fluid being pumped from each end and out through the centre. The screw shafts are carried in roller bearings at the drive end and ball bearings at the non drive (gearcase) end. The driven (lower) screw is synchronised from the driving (upper) screw by a pair of hardened and ground timing gears.

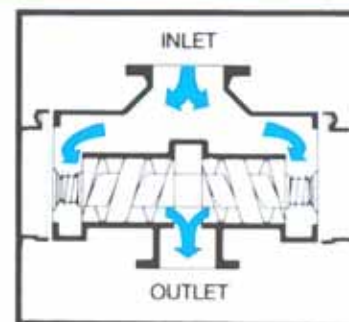

OUTBOARD BEARING PUMPS (for non lubricating liquids) are equipped with four mechanical seals keeping the bearings and timing gears external from the pumped liquid. Drive end roller bearings are provided grease packed. An oil bath is provided at the non drive end for splash lubrication of the timing gears and ball bearings.

INBOARD BEARING PUMPS (for lubricating liquids) are provided with one mechanical seal on the drive shaft only. The liquid being pumped lubricates the bearings and timing gears.

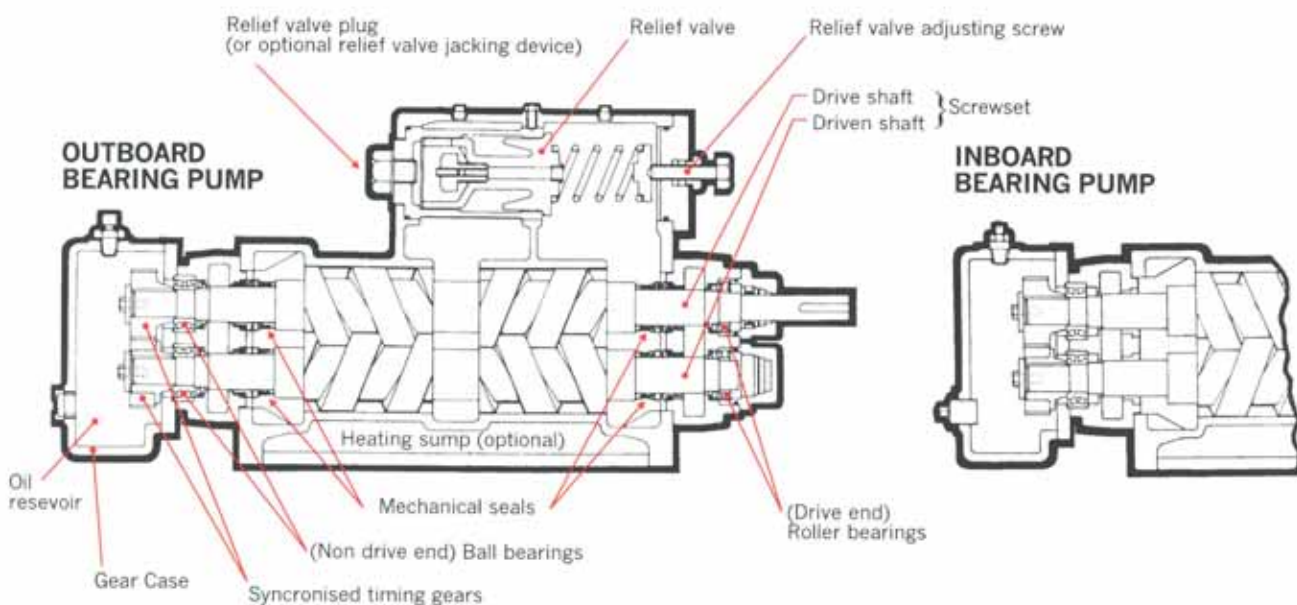

Relief Valve Design and Operation

The valve is of the disc type with an attached dashpot and spring. Under normal operation a very small proportion of liquid from the pump discharge leaks past the clearances between the skirt and the cylinder (Fig. 1). To prevent pressure building up the liquid drains back to suction through orifice "O".

Under pressure build up the relief valve starts to open, against the spring, exposing slot "S" to discharge pressure (Fig. 2). This allows the pressure to enter area "A" and quickly complete the opening of the relief valve to fully by pass the flow.

When the pressure drops the spring pushes the disk back on the seat forcing the liquid in area "A" back through slot "S". When the slot "S" is completely blanked off by the cylinder wall all the liquid is constrained to flow back through the orifice "O". This constraint has a dampening effect which prevents the relief valve slamming onto its seat.

Rapid Opening, Controlled Damped Closing.

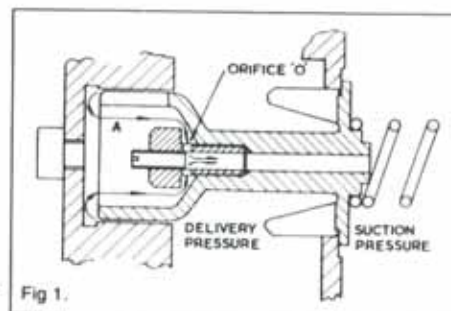

Fig 1.

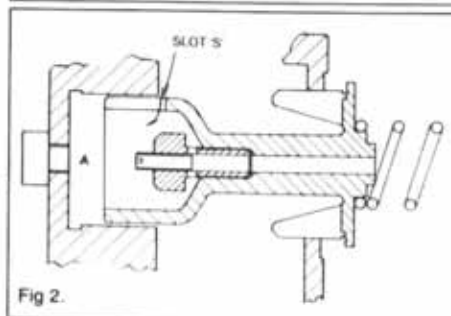

Fig 2.



Pump Features

Accurate Screw Profile
(High volumetric efficiency).

No contact between
intermeshing screws.

Double suction. End suction/
centre discharge, on screwset.
(Screwset in hydraulic balance).

Choice of screwset pitch angle.

Individual pitch selection.

Standard seal chamber
(to DIN 24960 (L1N or L1K
with spacer)).

Full flow relief valve.
Dashpot design.
(Rapid opening
damped closing).

Relief valve jacking device.

Fully machined one piece
baseplate. (Cast iron or
fabricated steel).

Drip rim and grout facility

Heating sump
(for oil or steam).

Liquid weir in suction
port chamber.

Option of seal face lubrication
for dry running start.

Dry start and stop running
(limited time).

Self priming.

Solid one piece shaft from
which screw shape is cut.

& User Benefits

Low running cost.

Can handle lubricating or non
lubricating liquids.
Very low wear.

Smooth axial pulse free flow
Low vibration } environmentally
Low noise } friendly.

Wide flow range.

For precise flow rate matching.

Customer choice of mechanical
seal and seal type for plant
standardisation.

No destructive pressure surges.
Added safety.
Smooth operation
Lower power at RV operation.

Allows manual operation of
relief valve without disturbing
spring setting.

Optimum strength.
Minimum distortion.
Accurate coupling alignment
maintained.

Ease of installation.
Maintenance flexibility.

Maintains hot liquid at required
temperature.
Prevents cold start damage.

Maintains wetted screwset for
dry start.

Reduce risk of seal face heat
damage on dry running start.

To enable full unloading and
loading cycles to take place.

Can evacuate air from
suction lines.

Maximum accuracy.
Minimum deflection from high
discharge pressure.

Relief Valve Jacking Device

As an option TWINRO pumps can be fitted with a jacking device to manually lift the relief valve off its seat. This has the operational advantage of being able to circulate pumped liquid around the pump to aid extreme discharge or suction conditions. The device has proved extremely useful in aiding cold start conditions where the liquid in the discharge line is below normal pumping temperature. Another useful application is the partial circulation of discharge liquid back to suction to aid suction lift applications at the end of barge or tank emptying.

OPERATION OF THE JACKING DEVICE DOES NOT ALTER PRE SET RELIEF VALVE SPRING PRESSURE.

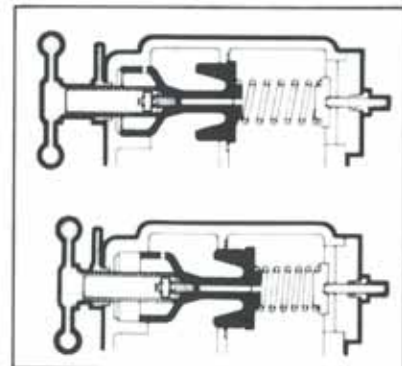



TWINPRO

Construction Feature	Stock Components	Special Order
Casing and Covers	Cast Iron Cast Steel	S.G. Iron Stainless Steel Bronze
Screwset	Carbon Steel	Stainless Steel
Mechanical Seals	DIN 24960 LiN Long series	DIN 24960 LiK short Series (with Spacer)
Relief Valve	Integral with Pump	Blanked off (for System Relief Valve) Relief Valve Jacking Device
Baseplate	Channel Steel Fabricated Steel Cast Iron (with Drip Rim Drain and grout facility)	Drip Rim Drain and Grout facility on steel base
Coupling	Flexible Non Spacer Type	Flexible Spacer Type
Coupling Guard	Aluminium	Steel Brass
Paint Finish	Standard Industrial System	Two pack epoxy or other systems for Hostile and Offshore Environments
Testing	Standard Works Pressure and Performance Tests	Witnessed Tests Noise and Vibration Tests NPSH Test Custom Tests Plotted Test Curves

FLOW RANGE

(Pump frame size is nominal design flow in M³/Hr. e.g. W80 is nominally a 80M³/Hr Pump).

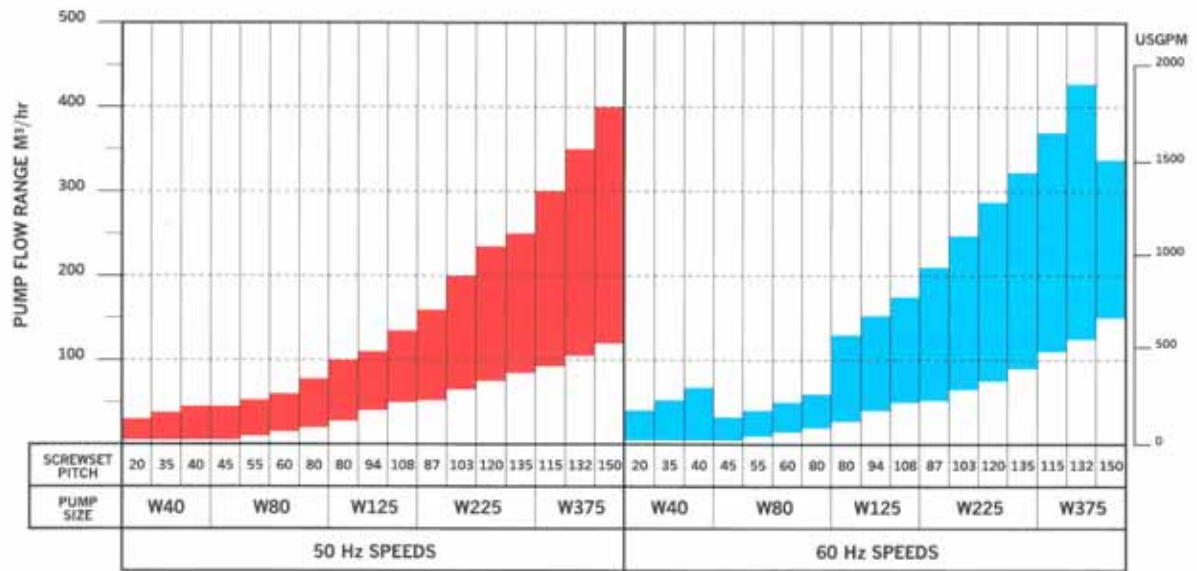

APPROXIMATE DIMENSIONS

(The W40 size is also available in vertical format).

	W40	W80	W125	W225	W375	Standard flanges are to ANSI dimensions IRON - ANSI 125FF, STEEL - ANSI 150RF DIN PN16 flanges are also available
SUCTION	4"	4"	6"	8"	10"	
DISCHARGE	4"	4"	6"	6"	8"	

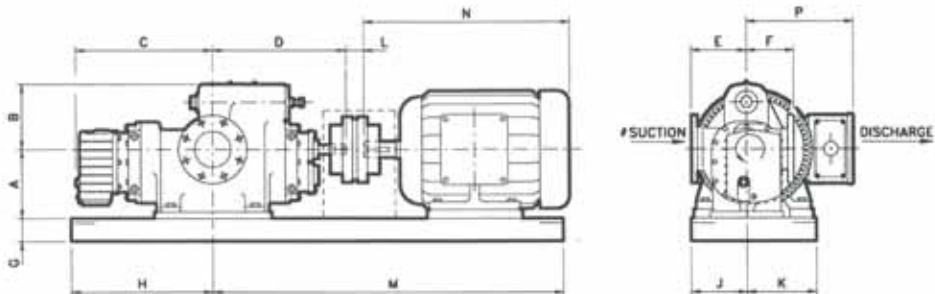

*Pumps can be constructed with suction left (as shown) or suction right, to suit installation.

Approximate dimensions (Inches). DO NOT use for installation purposes.

PUMP SIZE	PUMP ONLY							UNIT					*ELECTRIC MOTOR			
	A	B	C	D	E	F	G	H	J	K	L	FRAME	M	N	P	
W40	11.80	16.35	17.10	13.40	12.20	12.20	4.75	18.10	13.80	13.80	2.25	182T	29.50	15.50	9.50	
												365T	47.25	35.70	19.50	
W80	7.85	10.25	20.05	19.30	7.65	6.50	4.75	21.65	12.80	14.75	2.25	182T	39.40	15.50	10.50	
												405T	53.15	37.30	20.50	
W125	11.00	11.40	22.45	21.85	9.05	7.90	4.75	24.60	12.60	14.95	3.00	215T	44.30	19.90	12.55	
												444T	60.00	40.65	21.40	
W225	12.40	13.60	27.90	24.45	11.80	9.85	4.75	30.50	13.20	16.35	3.00	256T	54.15	25.60	14.00	
												449T	73.80	49.35	23.05	
W375	14.00	15.35	30.35	29.10	13.80	11.80	4.75	30.50	12.80	16.75	3.00	286T	62.00	27.95	15.50	
												449T	73.80	49.35	23.40	

*Dimensions are given for the smallest and largest motor sizes for each pump.

TWINRO