

Heavy Duty Side Entry Mixers

Technical Manual

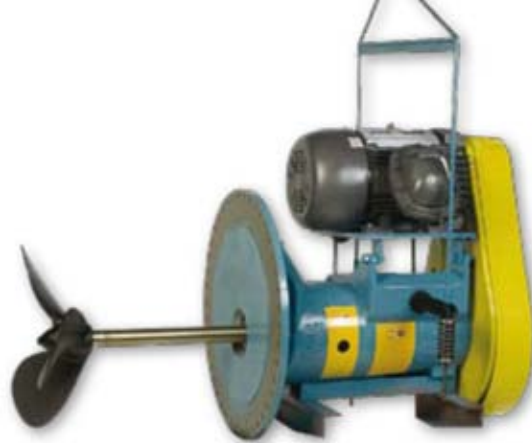
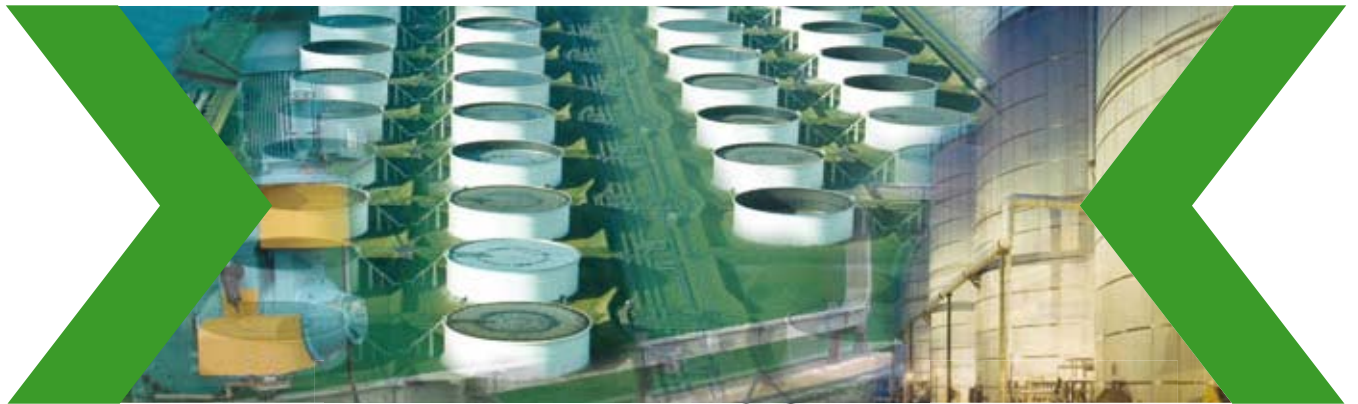

Plenty High-Efficiency, Heavy-Duty Side Entry Mixers for the Optimum in Tank Farm Agitation

Plenty has been associated with quality engineering since the year 1790 when the founder William Plenty established the company to manufacture plows and agricultural equipment for the local farming community.

From this humble beginning over 200 years ago, Plenty's engineering successes have progressed from the development of this late eighteenth century plow to some of the most sophisticated processing equipment.

Over recent years Plenty has undergone several organizational changes and in September 2001 they were acquired by the SPX Corporation.

Plenty Mixers now forms part of SPX Process Equipment within the Flow Technology Segment. SPX Process Equipment is comprised of Bran+Luebbe (pumps, systems and analyzers), Johnson Pump (pumps), LIGHTNIN (mixers), Plenty (side entry mixers and pumps), Premier Mill (milling, mixing and dispersing equipment), Tigerholm (de-aerators, connections, hoses, regulators), Waukesha Cherry-Burrell (pumps, valves, fittings, and heat exchangers), and WCB-Flow Products (fittings and valves).

Backed by over 50 years operating experience and with a reference list of successful site installations that is second to none, Plenty is acknowledged to be the market leader in the field of side entry mixing technology for the oil and petrochemical industries, having supplied literally thousands of units worldwide to numerous major oil companies in over 60 countries scattered around the globe.

Plenty side entry mixers have always set the industry international standard. They will out perform any other mixer on the market simply by virtue of their technically advanced design, which includes a simple and easily maintainable design, as well as a high efficiency, true helical pitch one piece 'cast' impeller incorporating high blade area and forward rake which was developed by Plenty.

Index

Plenty High Efficiency, Heavy Duty Side Entry Mixers for the optimum in tank farm agitation	2
Plenty High Efficiency Side Entry Mixers	3
Standard Design Features.....	4
Unique Side Entry Mixers Tank Shut-off Device.....	5
Side Entry Mixer Types.....	6
Fixed Angle Heavy Duty Belt Driven	8
Technical Data: Fixed Angle Belt Drive	9
Swivel Angle Heavy Duty Belt Driven	10
Technical Data: Swivel Angle Belt Drive	11
Fixed Angle Heavy Duty Gear Driven.....	12
Technical Data: Fixed Angle Gear Drive.....	13
Swivel Angle Heavy Duty Gear Driven.....	14
Technical Data: Swivel Angle Gear Drive	15
Criteria for Side Entry Mixer Tank Agitation	16
Recommended Mixer Orientations	18
Tank Mounting Details	19
Process Operation Details	20
Mounting Flange Details	21
Recommended cut out dimensions of floating roof tanks fitted with Fixed Angle mixers	22
Typical Site References	24

Plenty High-Efficiency Side Entry Mixers

Why Side Entry Tank Mixers?

The **Plenty** Side Entry mixer is the most efficient converter of energy into fluid motion. Unlike jet mixer systems, they do not suffer significant energy losses at the pump, in the pipework, in the bends, or most significantly, at the jet nozzles. Also, capital costs are lower and access to intank components is not restricted, while the problem of frequent, urgent maintenance on tanks that must be emptied and cleaned, is eliminated. Side Entry mixers are also more efficient than top entry mixers, and are significantly less expensive for larger diameter tanks. Side Entry mixers are ideal for use on tanks with floating roofs where practical considerations preclude the use of top entry mixers.

A properly selected side entry mixer, complete with a reliable shut-off device and high efficiency impeller out performs all other mixing devices.

Standard Range

- 3 - 75 HP
- 16" to 33" diameter impellers
- Belt and Gear Drive
- Fixed and Swivel Angle

These four variables form the comprehensive standard range. In every case the design concept has been to provide units suitable for long and continuous operation at remote sites with minimum maintenance.

Model Designation

All **Plenty** Side Entry mixers have designated model numbers in line with the following example:

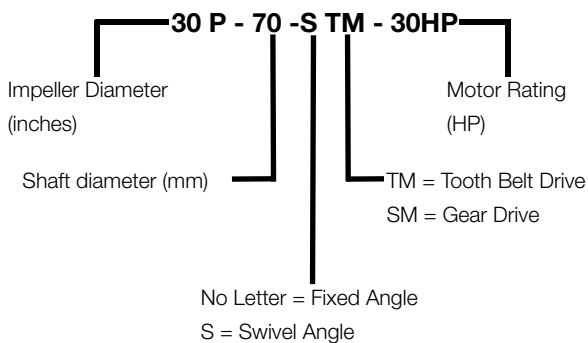

Belt Driven Units

These are flexible powergrip high torque drive (HTD) reinforced anti-static tooth belts for longer life with a minimum service factor of 1.5. The whole transmission is enclosed in a weatherproof, non-sparking guard with a fire resistant resin. Bearings are hermetically sealed for life, fully grease packed, with life ratings ISO and ANSI in excess of 47,000 hours.



Tooth Belt Mixers



Gear Driven Units

Utilize high efficiency case hardened spiral bevel gears to AGMA Class 2 having a minimum service factor of 1.5 for longer life. The gearbox may be removed as a unit for shop maintenance without disturbing motor mounting alignment or moving coupling halves. The **Plenty** gearbox achieves positive splash oil lubrication to all rotating components, effects low noise emission and maximum heat dissipation. There is no danger of lubrication failures and over heating which can occur with pump circulation systems. All bearings are open cage type with life ratings ISO and ANSI in excess of 44,000 hours.

Standard Materials of Construction

- | | |
|-------------------|--------------|
| ■ Impeller | Cast Iron |
| ■ Shaft | Carbon Steel |
| ■ Mounting flange | Carbon Steel |

Special materials such as stainless steel wetted parts or other exotic materials, etc., may be provided to suit individual requirements.



Gear Drive Mixers

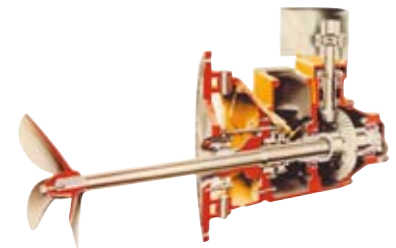

Standard Design Features

All Plenty Side Entry Mixers Incorporate the Following:

Impeller

The high efficiency **true helical pitch** impeller with **forward rake** was originally developed by **Plenty** for Side Entry mixers. Years of research in the field of liquid dynamics have been rewarded by a technically advanced design of impeller, having a **large blade area** that provides the optimum cavitation-free suction conditions promoting maximum pumping rate and entrainment for any installed power. Each impeller is accurately cast as a **one-piece** component, thus eliminating the setting variances and welding problems often present with alternative fabricated designs. Rigid inspections of pitch, uniformity and balancing ensures minimal vibration and optimum pumping efficiency.

Advanced Impeller Design

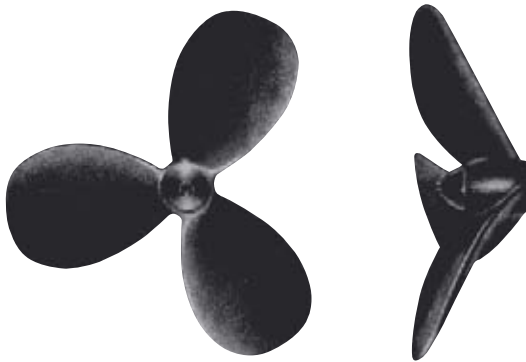

- High Pumping
- Minimum Power Draw
- Solid One Piece Design
- High Thrust
- No Cavitation
- Reliability

Impeller Fixing

Positive fixing and driving of the impeller on the shaft is achieved by the use of taper to taper shaft connection with side fitting key and retaining bolt.

1st Critical Speed

Tooth Belt Unit			Gear Driven Unit	
Model	KW	HP	Model	RPM
TM	2	3	SM 2	1647
TM	4	5	SM 4	1296
TM	5	7.5	SM 5	1266
TM	7	10	SM 7	1238
(S) TM	11	15	(S) SM 11	1880
(S) TM	15	20	(S) SM 15	1725
(S) TM	18	25	(S) SM 18	1320
(S) TM	22	30	(S) SM 22	1213
(S) TM	30	40	(S) SM 30	1179
(S) TM	37	50	(S) SM 37	1142
(S) TM	45	60	(S) SM 45	1110
(S) TM	55	75	(S) SM 55	1089

fig. 1

Bearings

In every case the units are designed and manufactured to require minimum maintenance. The mixer bearings in particular have been engineered to provide long life and have minimum B.10 lives as shown in fig.2. The figures are those of lowest life bearing - other bearings have greater B.10 lives.

Gear Driven Mixer

The bearings of the gear driven units are all open caged type including the input pinion gear support bearings. All these bearings are **splash oil mist lubricated** via lubrication channels in the gearcase.

Belt Driven Mixer

The bearings of the belt driven units are all prepacked with grease and "sealed for life" i.e. do not require regreasing. Note: All information given in fig.2 on bearing life is based on the fact that 90% of a large group of identical bearings can be expected to attain or exceed the life stated. This is called the basic rating life and conforms with both ANSI and ISO standards. The majority of bearings attain a much longer life than this; the median life is approximately five times the calculated basic rating life.

Shaft

The shaft has been designed to minimize misalignment, deflection and vibration which all affect the mechanical seal and bearing life. It is a **one-piece** component with no intermediate couplings and is ground between centers at the bearing and seal areas. All shafts are **engineering hard-chrome plated** in seal and shut-off areas. The range of **Plenty** mixers has been designed for heavy-duty operation and the large diameter shafts have a first critical speed of at least **250%** of the operating speed as shown in fig.1. The shaft is supported by heavy duty antifriction bearings, outboard of tank product, making maintenance easier and allowing the performance to be monitored.

ISO/ANSI Bearing Life

Tooth Belt Unit			Gear Driven Unit	
Model	KW	HP	Min. B.10 Hours	Min. B.10 Hours
TM	2	3	1,946,00	422,000
TM	4	5	564,005	128,000
TM	5	7.5	537,000	66,000
TM	7	10	173,000	45,000
(S) TM	11	15	157,000	(S) SM 11 144,000
(S) TM	15	20	93,000	(S) SM 15 81,000
(S) TM	18	25	51,000	(S) SM 18 48,000
(S) TM	22	30	91,000	(S) SM 22 221,000
(S) TM	30	40	63,000	(S) SM 30 84,000
(S) TM	37	50	47,000	(S) SM 37 44,000
(S) TM	45	60	60,000	(S) SM 45 85,000
(S) TM	55	75	47,000	(S) SM 55 56,000

fig. 2

Unique Side Entry Mixer Tank Shut-off Device

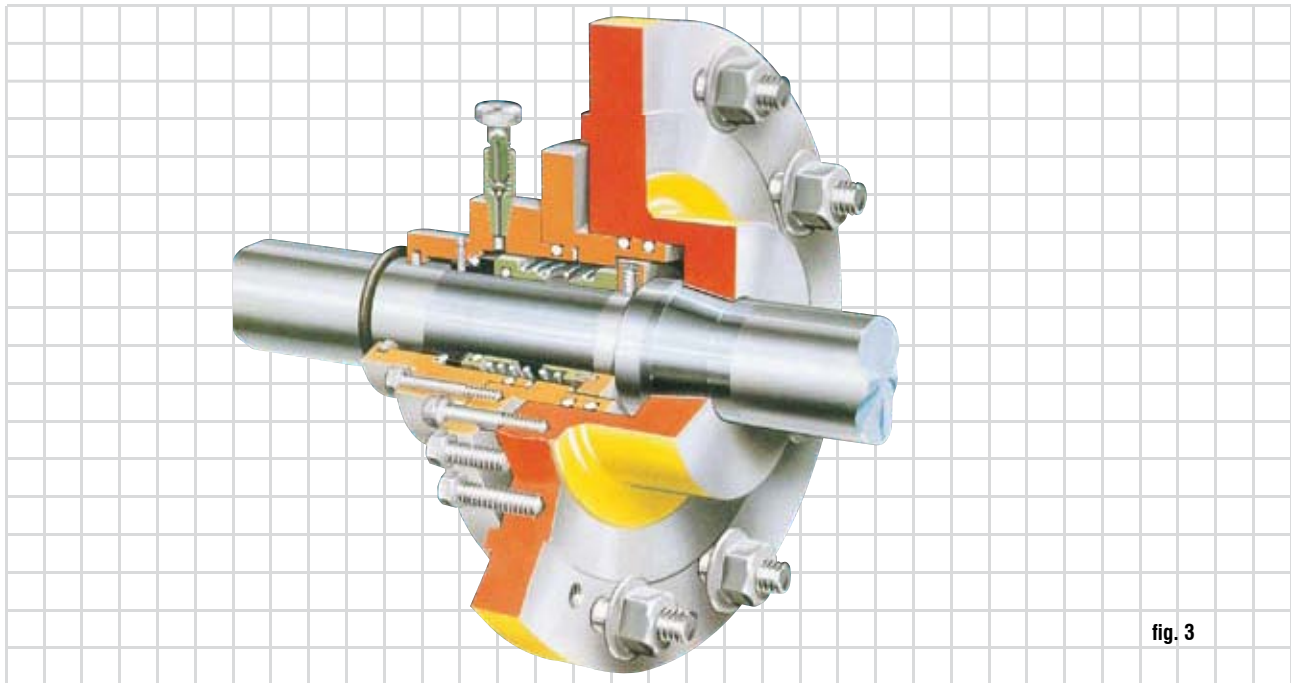

fig. 3

Tank Shut-Off Mechanism

All units incorporate a tank shut-off device to allow the shaft seal and bearings to be changed under full tank conditions. (See fig. 3, 4 & 5). The tank shut-off mechanism incorporates tapered metal to metal faces, positively clamped by a bolted flange which both seals products in the tank and securely supports the shaft during bearing and/or shaft seal changes. All tapered faces are wear and corrosion resistant.

The most important aspect of the **Plenty** mechanical seal assembly is that it incorporates a safety check valve for ensuring that the shut-off is **100%** effective **before** removal of any bearings or mechanical seal.

The **Plenty** shut-off mechanism offers complete safety and security as it does not incorporate any flexible 'O' rings or gaskets which deform, wear, or perish.

Mechanical Seal

The mechanical seal was developed in conjunction with a leading manufacturer for use in the Petrochemical field on fluids from asphalt to xylene.

The mechanical seal is completely enclosed inside a housing which is fitted with a close clearance throttle bush outboard of the mechanical seal to restrict leakage rate of tank media in the event of ultimate seal failure.

A safety check valve is fitted for venting the

seal chamber to ensure that it is completely filled with liquid prior to start-up as well as to check that the shut-off device is 100% effective. (See fig. 3, 4 & 5).

Alternative Seal Arrangements

- Double Mechanical Seal
- Cartridge Seal
- High Temperature Sealing Units

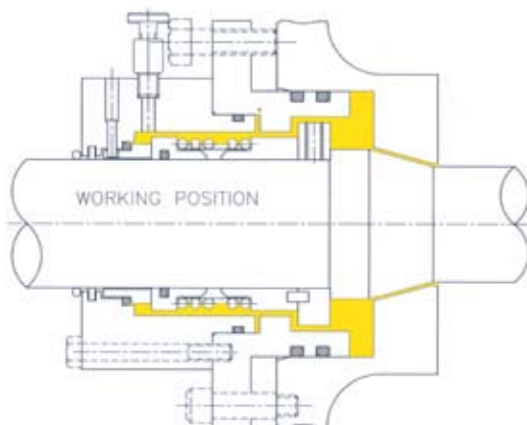

fig. 4

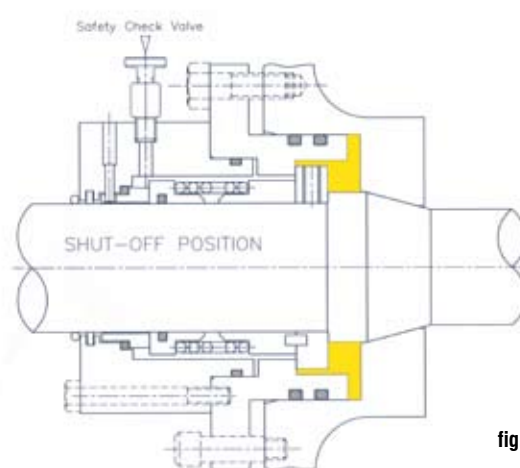

fig. 5

Side Entry Mixer Types

Fixed Angle

Normally used in **blending** applications, maintaining **homogeneity**, aiding **heat transfer** or to maintain **temperature uniformity**. All these applications demand complete top to bottom turnover and for this purpose mixers are permanently installed at an angle of 10° to the left of the tank axis.

Swivel Angle

Swivel Angle mixers incorporate a feature which allows the mixer angle of entry to be varied through 30° either side of the tank center-line in 10° increments and enables the entire tank floor to be directly scoured by the impeller flow stream. This is the **only** satisfactory solution to **B.S. & W.** control in large tanks and ensures that the heavy solids, water and corrosive salts which settle in areas least agitated by a permanently fixed mixer are maintained in suspension.

The mixer module is supported by two hinge bearings which ensure ease of manual angle changing and the swivel seal is effected by a heavy duty static solosele acting on a stainless steel spherical ball (See fig. 6 & 7). As an alternative to this manual facility, an automatic swivel actuator can be supplied as an optional extra.



fig. 6: Swivel Ball

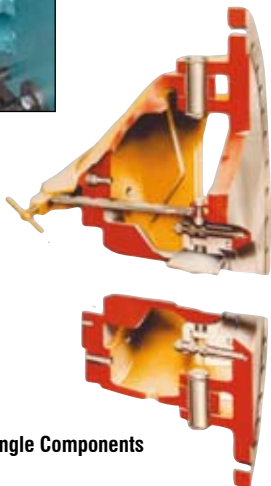

fig. 7: Swivel Angle Components

Mounting Support Slings

All Mixers can be installed without support slings, but in view of the already highly stressed condition of large tanks in particular, we recommend that all mixers over 1550 lbs. (all 70 & 85mm units) are fitted with support slings to dissipate the load over as large an area as possible. The standard support slings incorporate variable load settings to accommodate tank shell movement during filling and emptying. (See fig. 8).



fig.8: Variable Load Support Sling Detail

Castor Support

A castor support is available for Fixed- and Swivel Angle Mixers as an alternative to support slings. (See fig.9). This serves the same purpose as the mounting support slings and can be used where welding support sling brackets to the tank shell are impractical.



fig. 9: Castor Support on Belt Mixer

Coupling - Gear Driven Unit

The standard unit incorporates a flexible non-lubricated coupling utilizing a double stainless steel membrane pack specifically designed for oil refinery service. The membrane pack facilitates removal of the gearbox without disturbing electric motor alignment. The coupling is totally enclosed by a fully sparkproof and corrosion resistant guard. (See fig.10).



fig. 10: Gear Mixer Coupling

Gear Box Lubrication System

The **Plenty** gearbox achieves positive lubrication to all rotating components. The oil reservoir capacity is designed such that the gearwheel ‘picks up’ oil, providing the necessary meshing oil film at the pinion and displacing ‘oil mist’ up the lubrication channel to the top pinion bearings. The oil then floods downward through the bearings into the pinion/wheel meshing.

Each gearcase has a magnetic plug fitted to remove any foreign metallic particles that may be present. Oil level windows are fitted as standard.

Automatic Swivel Actuator

The Automatic Swivel Actuator is an electric motor driven speed reducer and linkage, which allows the mixer to swivel 30 degrees in either direction. The timer controller provided will cycle on even 24 hours and swivel the mixer 10 degrees each time. This allows for efficient cleaning of the tank bottom and eliminates the need for routine manual adjustment.



Plenty Automatic Actuator



Timer Control Panel

Optional Design Features

- Seal leakage detector
- Bearing probe wear monitoring unit
- Special mechanical seals
- Hand operated swivel actuator
- Automatic swivel actuator
- Vibration detectors

Spare Parts and Interchangeability

The number of spare parts which a refinery needs to stock are considerably reduced by the component standardization inherent in each design. A comprehensive stock of standard components is held to provide a guaranteed supply in the event of a breakdown.

Quality Control

Each mixer is subject to rigorous quality control checks throughout the various stages of manufacture and to a standard works no load running test. Witnessed testing is possible by prior arrangement.

Process Guarantee

All **Plenty** Mixers carry a process guarantee, provided :

1. ALL process details are supplied with the inquiry and the expectation of the process is provided before the selection is made.
2. The requirement for the process guarantee is declared at time of inquiry.
3. The mixers are installed, operated and maintained according to the SPX – Plenty Installation, Operations and Maintenance Manual.

Fixed Angle Heavy-Duty Belt Driven

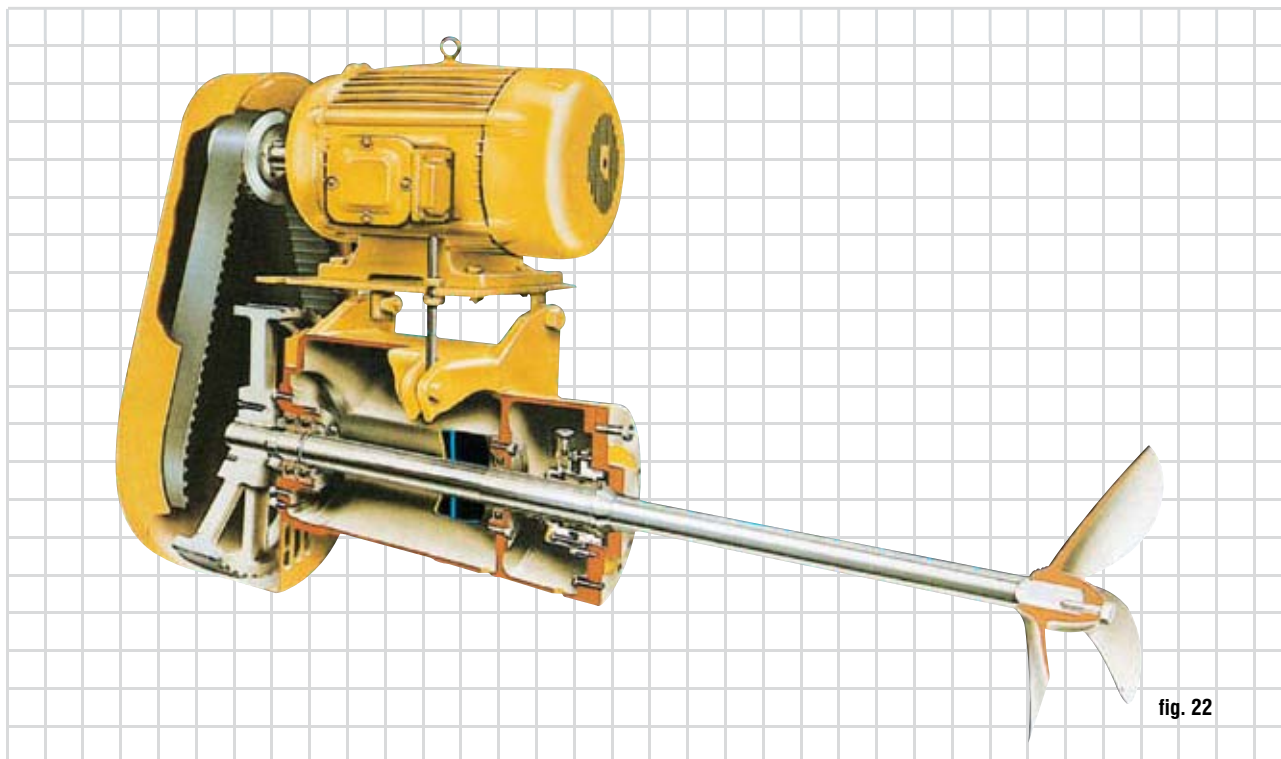

Specification Model TM

Driven by a horizontal foot mounted motor fitted above the main mixer frame on a steel mounting plate with a hinged adjustment for correct belt tensioning. Hinge pins and adjusting screws etc. are corrosion protected against atmospheric corrosion. The motor and mixer shafts are connected by a Fire Resistant Anti Static (FRAS) High Torque Drive (HTD) Tooth Belt adequately sized to transmit motor power. The pulleys have taperlock bushes for ease of removal and are enclosed in a sparkproof and weatherproof

guard. Drive service factor is 1.5 minimum. The main mixer frame is a rigid one-piece casting spigot located to the steel mounting flange and incorporating pre-lubricated, sealed for life, hermetically sealed shaft bearings. The mounting flange incorporates a single mechanical seal with a corrosion and wear resistant tank shut-off device permitting seal and bearing replacement under full tank conditions. A close clearance throttle bush is fitted outboard of the mechanical seal to limit the leakage rate in

the event of seal failure. Optional tank adaptor flanges can be supplied to suit all tank manhole/ nozzle fixings. The mixer shaft is hard chromed in the shaft seal and shut-off area and fitted with a one-piece cast, three-bladed, high efficiency, special pitch impeller, balanced and keyed in position.

Technical Data: Fixed Angle Belt Drive

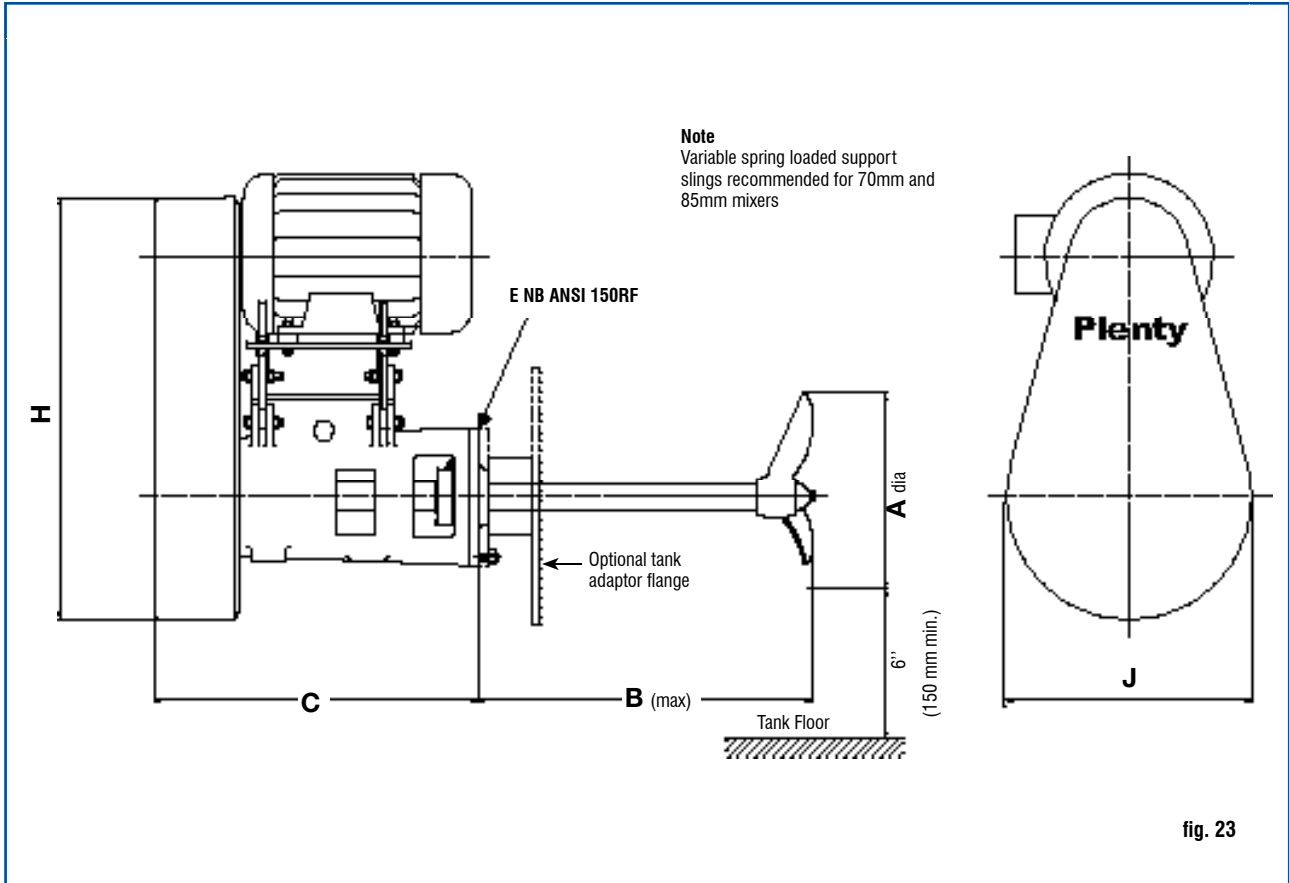

Shaft DIA: AT SEAL.		45 mm	60 mm	70 mm	85 mm
Drive					
*Nominal RPM		431	440	406	409
A (Dia)		To Suit Specific Process Conditions			
B	in. / mm	27 ³ / ₄ / 705	33 ³ / ₄ / 860	43 ¹ / ₂ / 1105	46 ¹ / ₂ / 1180
C	in. / mm	22 / 560	26 ³ / ₄ / 680	34 / 860	37 ³ / ₄ / 960
E (Bore)	in. / mm	8 / 203	8 / 203	10 / 254	10 / 254
H	in. / mm	23 ³ / ₄ / 600	36 / 910	45 ³ / ₄ / 1160	49 / 1245
J	in. / mm	15 / 380	22 ³ / ₄ / 575	28 ¹ / ₂ / 725	28 ¹ / ₂ / 725

* Based on 60Hz motors

Dimensions are approximate only and certified drawings will be supplied at time of order.

Swivel Angle Heavy-Duty Belt Driven

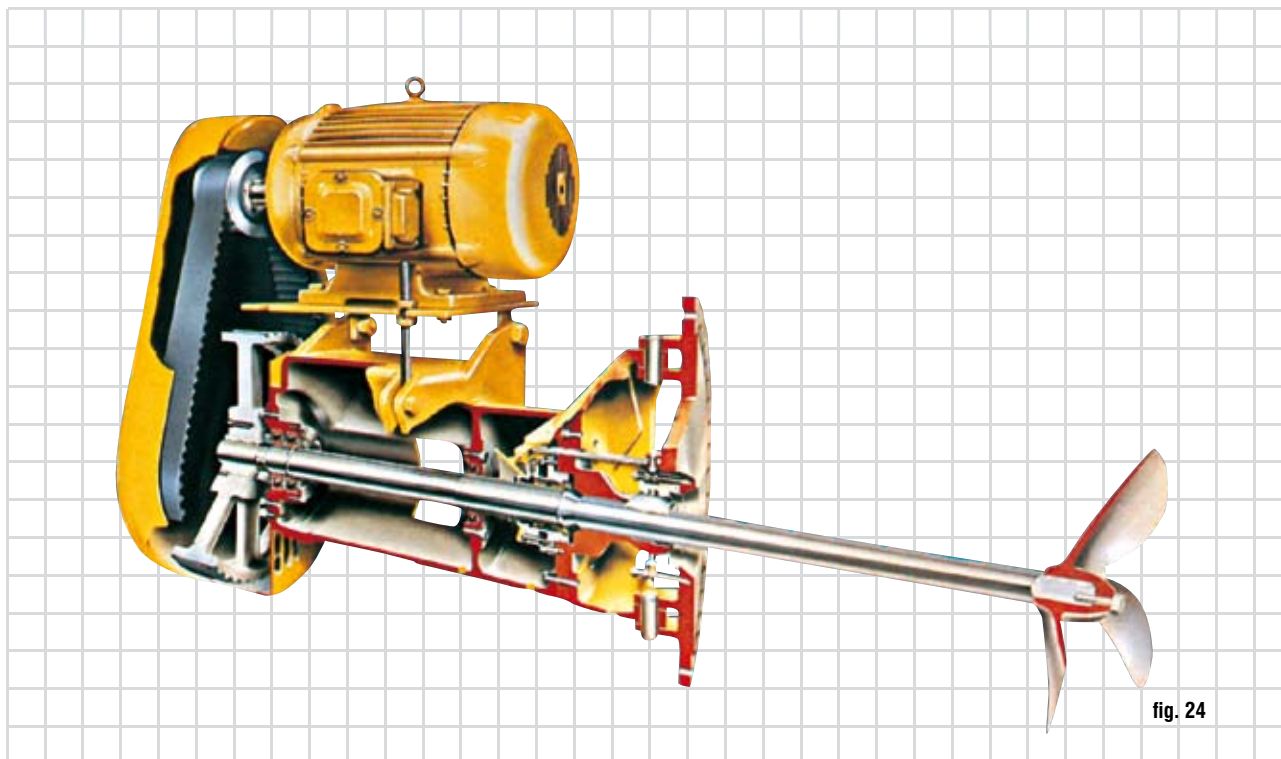

Specification Model STM

Driven by a horizontal foot mounted motor which is fitted above the main mixer frame on a steel mounting plate with hinged adjustment for correct belt tensioning. Hinge pins and adjusting screws etc. are corrosion protected against atmospheric corrosion. The motor and mixer shafts are connected by a Fire Resistant Anti Static (FRAS) High Torque Drive (HTD) Tooth Belt adequately sized to transmit motor power. The pulleys have taperlock bushes for ease of removal and are enclosed in a sparkproof and weatherproof guard. Drive service factor 1.5 minimum. The main mixer frame is a rigid one piece casting spigot located to the steel mounting flange and incorporating pre-lubricated, sealed for life, hermetically sealed shaft bearings.

The mixer frame is also spigot located to a swivel assembly which is flanged to suit the tank manway/nozzle. This swivel assembly comprises a stainless steel polished spherical ball integral with the mixer mounting

flange and sealed by a Viton Solosele which is adjustable to prevent leakage when the mixer is swivelled in a horizontal plane through 60 degrees (30 degrees either side of center). The mixer is supported by robust hinge pins and is provided with a positive clamping arrangement for locking the mixer in positions of 10 degree intervals. The **Plenty** automatic actuators can be fitted to this range.

The mounting flange incorporates a single mechanical seal with a corrosion and wear resistant tank shut off device permitting seal and bearing replacement under full tank conditions. The seal also has a close clearance throttle bush outboard of the mechanical seal to limit the leakage rate in the event of seal failure. The mixer shaft is hard chromed in the shaft seal and shut off area and fitted with a one piece cast, three-bladed, high-efficiency, special pitch impeller, balanced and keyed in position.

Technical Data: Swivel Angle Belt Drive

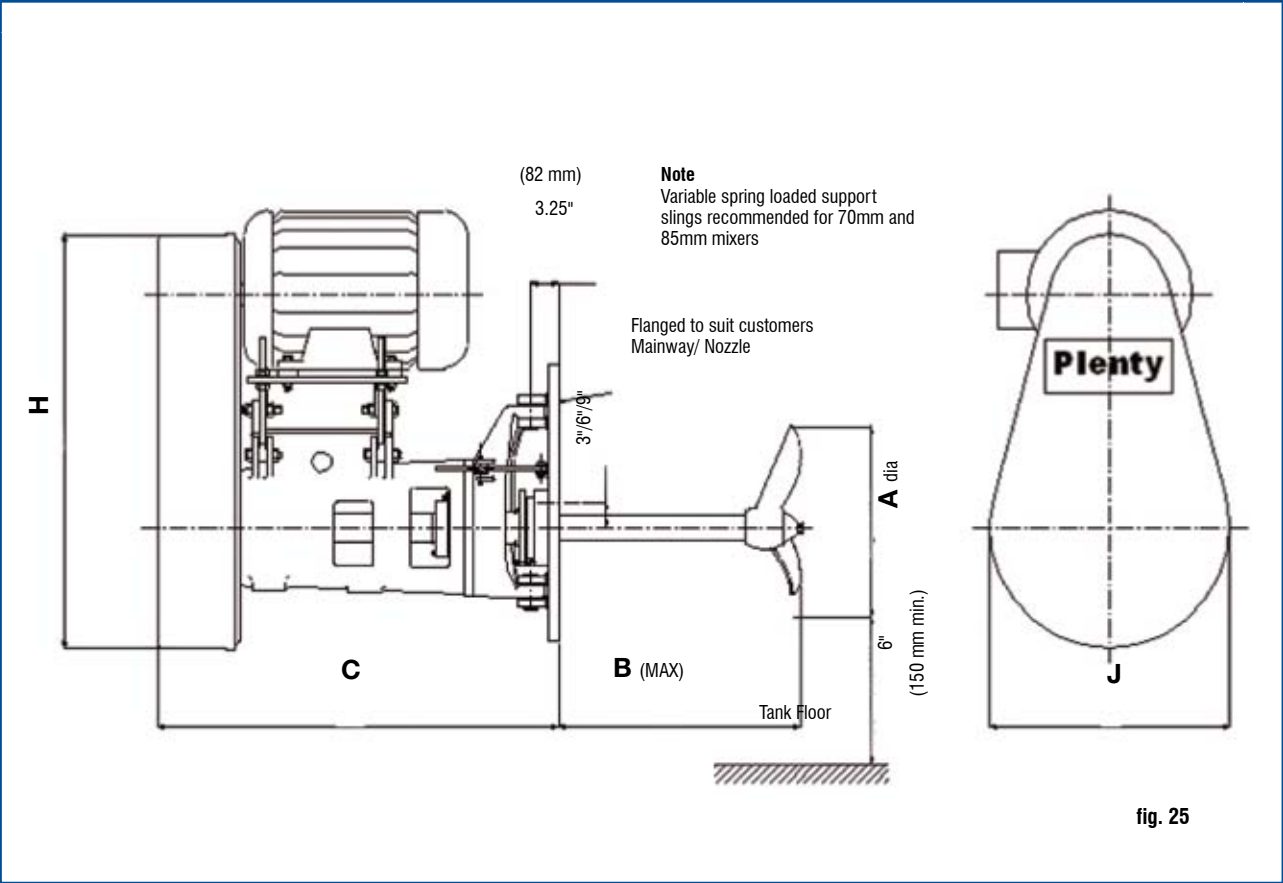

Shaft DIA: AT SEAL.		60 mm	70 mm	85 mm
Drive				
*Nominal RPM		440	406	409
A (Dia)		To Suit Specific Process Conditions		
B	in. / mm	27 ³ / ₄ / 705	33 ¹ / ₂ / 850	36 ¹ / ₂ / 925
C	in. / mm	37 / 935	43 ³ / ₄ / 1110	47 ¹ / ₂ / 1210
H	in. / mm	36 / 910	45 ³ / ₄ / 1160	49 / 1245
J	in. / mm	22 ³ / ₄ / 575	28 ¹ / ₂ / 725	28 ¹ / ₂ / 725

* Based on 60Hz motors

Dimensions are approximate only and certified drawings will be supplied at time of order.

Fixed Angle Heavy-Duty Gear Driven

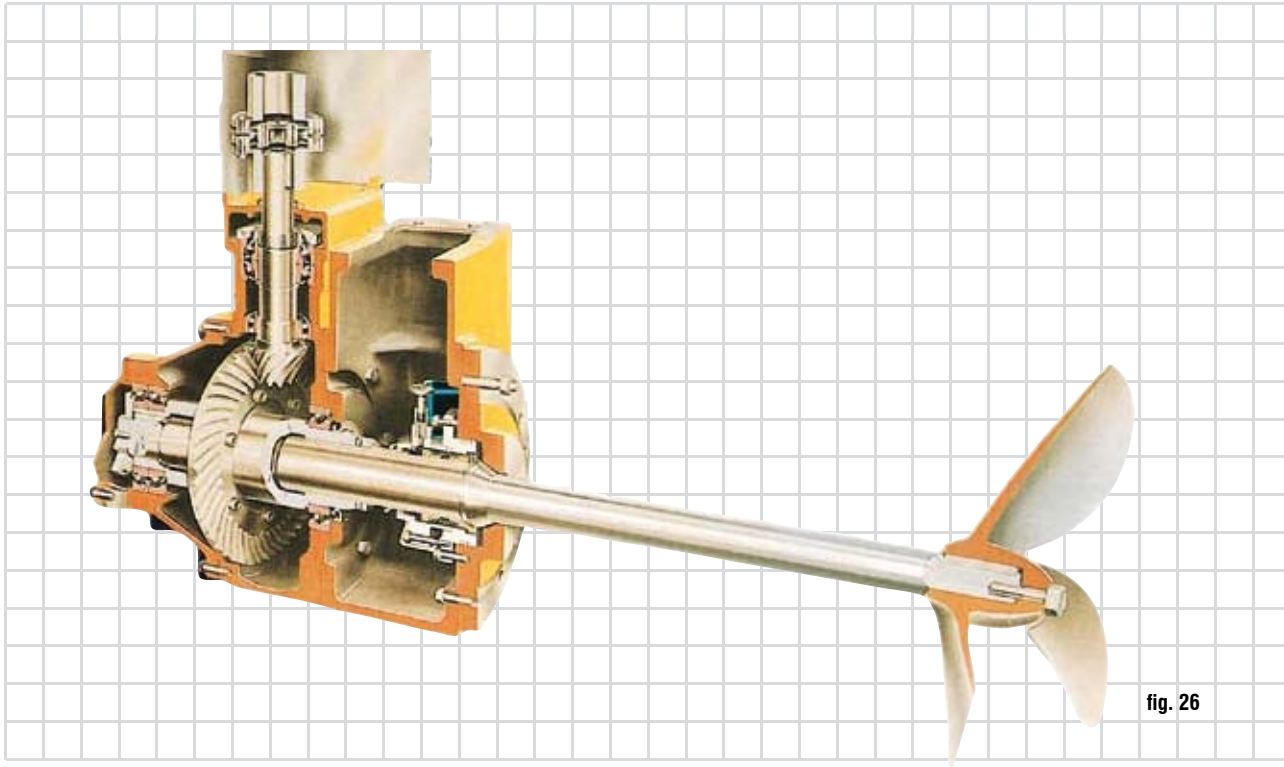

fig. 26

Specification Model SM

Driven by a vertical electric motor which is flange mounted on the support bracket above the gearbox and connected by an all metal flexible coupling protected by a guard.

The gearbox comprises a single reduction hardened high efficiency spiral bevel gear set having a minimum service factor of 1.5 to AGMA gear class 2. The gears and all bearings are splash oil lubricated and enclosed in a large gear case for maximum heat dissipation.

The mixer frame is a rigid one-piece iron casting spigot located on the gearbox and the steel mounting flange. Optional tank adaptor flanges can be supplied to suit all tank manhole/nozzle sizes.

The mounting flange incorporates a single mechanical seal with a corrosion and wear resistant tank shut-off device permitting seal and/or gearbox removal under full tank conditions. A close clearance throttle bush is fitted outboard of the mechanical seal to limit the leakage rate in the event of seal failure.

The mixer shaft is hard-chromed in the shaft seal and shut-off area and fitted with a one-piece cast, three-bladed, high-efficiency, special pitch impeller, balanced and keyed in position.

Technical Data: Fixed Angle Gear Drive

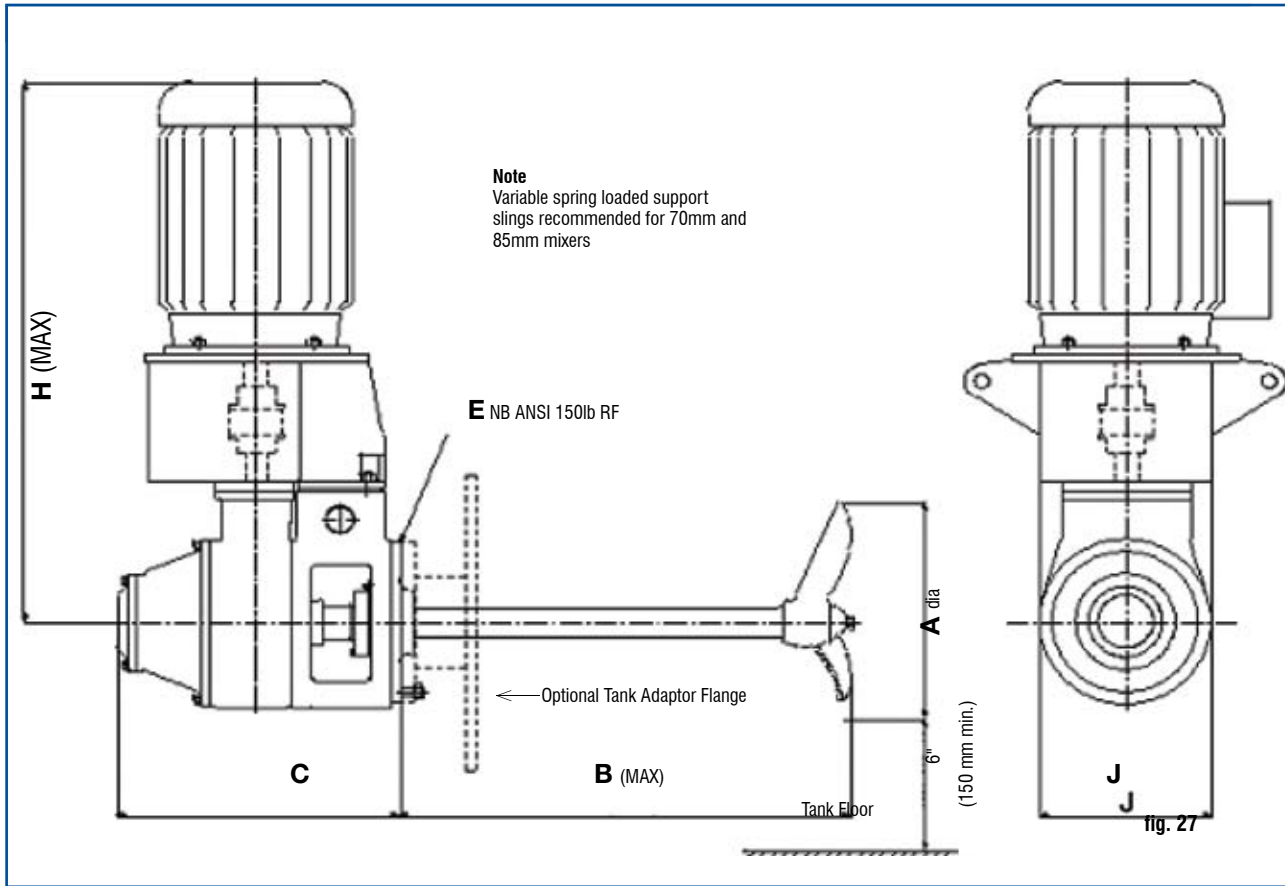

Shaft DIA: AT SEAL.		60 mm	85 mm
Drive			
*Nominal RPM		425	420
A (Dia)		To Suit Specific Process Conditions	
B	in. / mm	34 1/2 / 875	46 3/4 / 1185
C	in. / mm	20 1/4 / 515	27 1/4 / 695
E (Bore)	in. / mm	8 / 203	10 / 254
H	in. / mm	42 1/2 / 1076	58 / 1475
J	in. / mm	13 1/2 / 340	16 3/4 / 425

* Based on 60Hz motors

Dimensions are approximate only and certified drawings will be supplied at time of order.

Swivel Angle Heavy-Duty Gear Driven

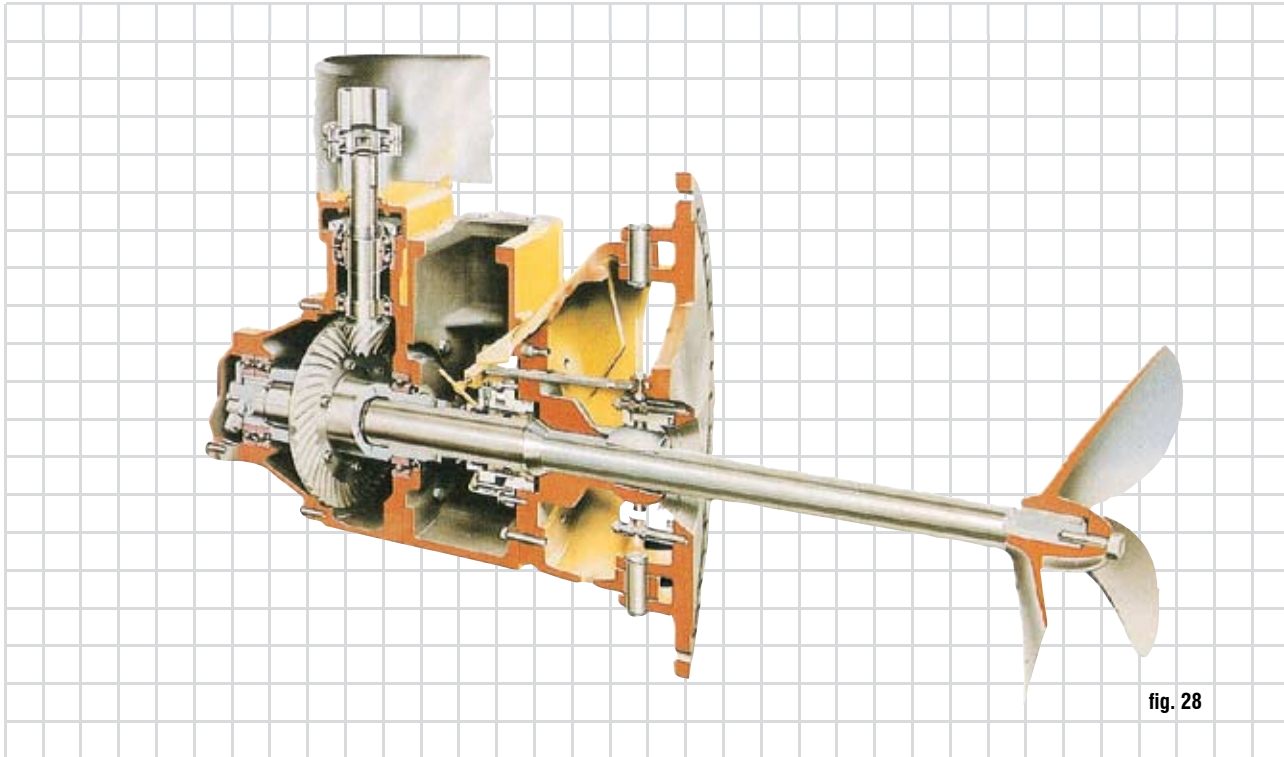

Specification Model SSM

Driven by a vertical electric motor which is flange mounted on the support bracket above the gearbox and connected by an all metal flexible coupling protected by a guard.

The gearbox comprises a single reduction hardened high efficiency spiral bevel gear set having a minimum service factor of 1.5 to AGMA gear class 2. The gears and all bearings are splash oil lubricated and enclosed in a large gear case for maximum heat dissipation.

The mixer frame is a rigid one-piece iron casting spigot located to the gearbox and the swivel assembly. This swivel assembly comprises a stainless steel polished spherical ball integral to the mixer mounting flange and sealed by a Viton Solosele which is adjustable to prevent leakage while the mixer is swivelled in a horizontal plane through 60° (30°

either side of a line through the tank center). The mixer is supported by robust hinge pins and is provided with a positive clamping arrangement for locking the mixer in positions of 10° intervals.

The mounting flange incorporates a single mechanical seal with a corrosion and wear resistant tank shut-off device permitting seal and/or gearbox removal under full tank conditions. A close clearance throttle bush is fitted outboard of the mechanical seal to limit the leakage rate in event of seal failure.

The mixer shaft is hard-chromed local to the shaft seal and shut-off area and fitted with a one-piece cast three bladed, high efficiency, special pitch impeller balanced and keyed in position.

Technical Data: Swivel Angle Gear Drive

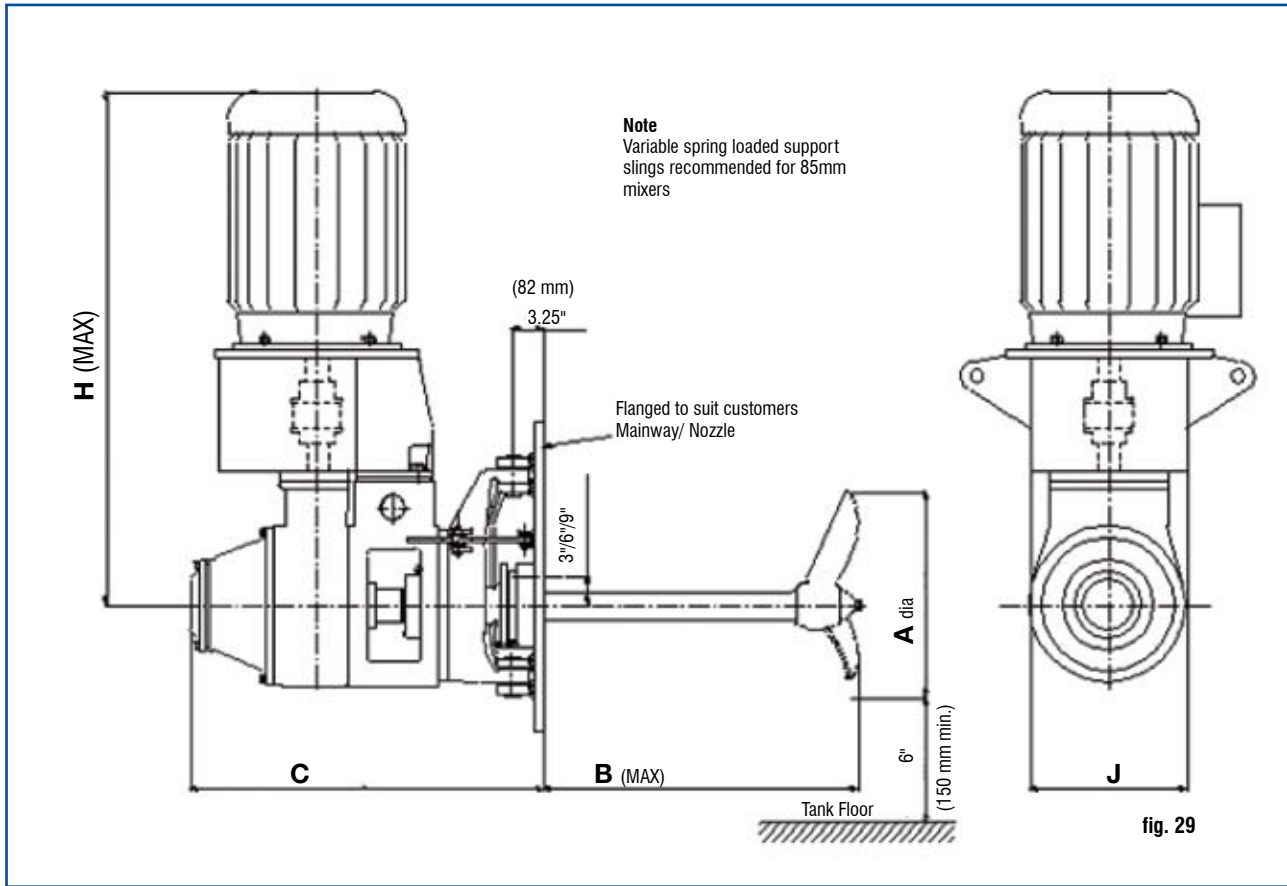

Shaft DIA: AT SEAL.		60 mm	85 mm
Drive			
*Nominal RPM		425	420
A (Dia)		To Suit Specific Process Conditions	
B	in. / mm	28 1/4 / 720	36 1/2 / 930
C	in. / mm	30 1/2 / 770	39 1/4 / 995
H	in. / mm	42 1/2 / 1076	58 / 1475
J	in. / mm	13 1/2 / 340	16 3/4 / 425

* Based on 60Hz motors

Dimensions are approximate only and certified drawings will be supplied at time of order.

Criteria for Side Entry Mixer Tank Agitation

A. Applications

The majority of Side Entry mixers are required to meet one or more of the following duties:

1. Crude Oil B.S. & W. Control

To control or prevent the accumulation of bottom sludge and water pockets (B.S. & W.) especially in Crude Oil Storage Tanks at Refineries, Terminals or Entrepôts. Demands high velocity circulation in order to completely scour the bottom of the tank

2. Maintain Homogeneity

To maintain homogeneity of refinery finished or intermediate products or chemical plant feed stocks to ensure uniform specification. This demands complete movement throughout the tank with top to bottom "turnover" as well as circulation round the tank, to ensure that the product at the top, middle and bottom remains uniform to specification. This may also sometimes apply to crude oil storage especially in refinery tanks feeding direct to the processing units.

3. Blend

To mix two or more different components to obtain a homogeneous blend in a specified time to specific requirements again demands complete top to bottom "turnover".

4. Heat Transfer

To aid heat transfer while heating or cooling or to maintain temperature uniformity - again complete fluid motion, top to bottom "turnover" would normally be required. Location of mixers relative to the heating element is also important to the success of the operation.

Note

It is possible that one or more of the duties may apply to a particular application and the most critical duty must determine the selection of mixer. Generally the most power demanding duty is blending, application 3.

B. Design Parameters

In general, all refinery Side Entry mixer applications require between .25 HP - 1 HP per 1000 bbl. In rare cases, for example B.S. & W. control of crude oil of very low viscosity and low B.S. & W. content, it is possible to install less power but only if the mixers are of the swivel angle type. For each application there is a minimum power below which no matter how long the mixer is operated a blend or homogeneity will never be achieved. For product storage tanks this figure is generally .25 HP per 1000 bbls.

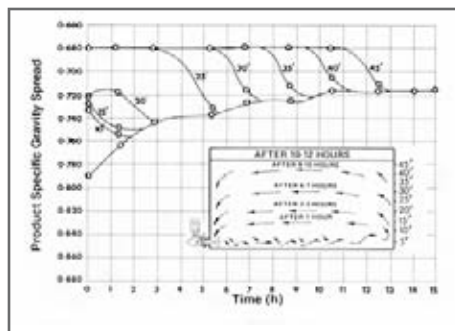

fig. 30

The power (P) required for a given duty is as follows:

$$P = \text{volume factor} \times \text{tank ratio factor} \times \text{viscosity factor} \times \text{gravity difference factor} \times \text{blend time factor}$$

This calculated power must not be less than the minimum power.

1. Tank Ratio & Geometry

Side Entry mixers induce a spiral jet flow across the floor of the tank continually entraining product from other areas of the tank. This jet stream initially only agitates the higher gravity product in the bottom of the tank, but in time, providing there is the necessary installed power, will gradually penetrate the higher layers of the tank product with sufficient velocity to generate both full top to bottom flow and to break the interface between the various densities and achieve a full homogeneous mix.

If the actual height/diameter (Z/t) ratio is excessive this will influence the total power required as shown in Fig.11 below.

Tank Volume bbl x 10 ³	Optimum Height/Dia. (Z/t Ratio)	Correction Factor for Higher Tank Z/t Ratios
.2	1.54	Actual Z/t Ratios / Optimum Z/t ratio (minimum 1.0)
.5	1.17	
10	.95	
25	.72	
50	.59	
100	.48	
250	.37	
500	.30	
600	.28	
750	.26	
1000	.24	

fig. 11

2. Viscosity

The viscosity of the product will also have an effect on the minimum and required power, to achieve movement throughout the tank. The higher the viscosity the greater will be its resistance to the flow generated by the impeller. Generally in viscosities below 50 cP the effect would be very slight, but above this it is very important to make corrections.

The viscosity factor would be tabulated thus:

Viscosity	Viscosity Factor
500 cP	1.5
1,000 cP	3.0
2,000 cP	5.0
3,000 cP	8.0

It is not common to perform tank mixing of products with viscosities as high as the last two examples as it is usually more economical to heat the products being handled to reduce the viscosity not only to keep the power levels of the mixers lower, but also the necessary power for the transfer pumps.

3. Density Difference

The density spread can have a considerable effect on the final mixer power. Generally speaking, the wider the difference between the density of the two or more components to be mixed the more power is required to break the interfaces between the components and achieve blend. If inadequate power is installed, insufficient fluid velocity would be developed to break down the interfaces. An indication of the effect which this variable has on the total mixer power required is shown below.

Density Difference	Specific Gravity Difference
°API	Factor
15	1.0
25	1.5
35	2.0

4. Time

It will be appreciated that to blend the tank contents in 12 hours would require approximately half the power required to do the same duty in 6 hours and approximately twice as much power as would be necessary in 24 hours.

It is, however, necessary to appreciate that some time is required to get the tank contents in motion before the necessary flow pattern is established to enable the mixing process to commence.

Additionally it should be understood that advantages can be obtained by operating the mixer(s) while filling the tank (see later discussion under 5).

As already discussed there is a minimum power required for a given volume below which the necessary fluid motion would never be developed for minimal process requirements.

5. Orientation, Multiple Mixers, Relation to Inlet and Outlet Connections

In order to maximize flow regime within the tank, **Plenty** experience shows that all mixers selected should be contained within a 90 degree quadrant and approximately 22.5 degrees apart. The positioning of the mixers on the tank depends upon the application.

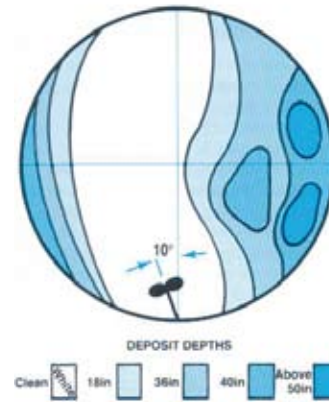

fig. 32

Crude Oil BS&W Control

The main purpose of the mixers in this application is to ensure the developed jet flow is used to lift the BS&W into the body of the crude oil to maintain a relatively clean tank floor. The Swivel Angle mixers used can be varied to direct flow up to 30 degrees either side of the center line of the tank, so that all areas of the tank are swept. It is particularly important to prevent sludge build up or blockage around the tank outlet so the mixer group should be situated directly opposite the tank outlet.

Blending, maintaining homogeneity and heat transfer

It is assumed that these duties are with 'clean' product and so Fixed Angle mixers are used. As with Swivel Angle mixers, all should be approx. 22.5 degrees apart and within a 90 degree quadrant. If it is possible to operate the mixers during 'pump up', up to 50% of process power or time can be saved. To maximize the additive mixer effect of inlet flow and mixer jet stream it is recommended that the mixer group be situated approximately 22.5 degrees to the left of the tank inlet. If it is not possible to utilize the 'pump up' time, the position of the mixer group is not critical.

Swivel Angle mixers locked in the 10 degree left position can be used for these duties.

Typical Contour of Tank Bottom Deposits after mixing with Plenty Swivel-Angle Side Entry Mixer

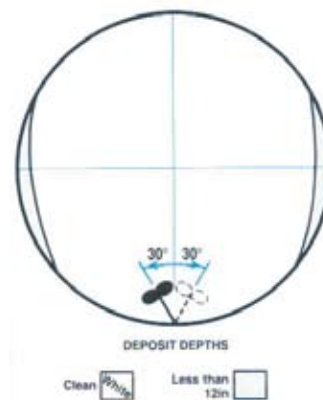
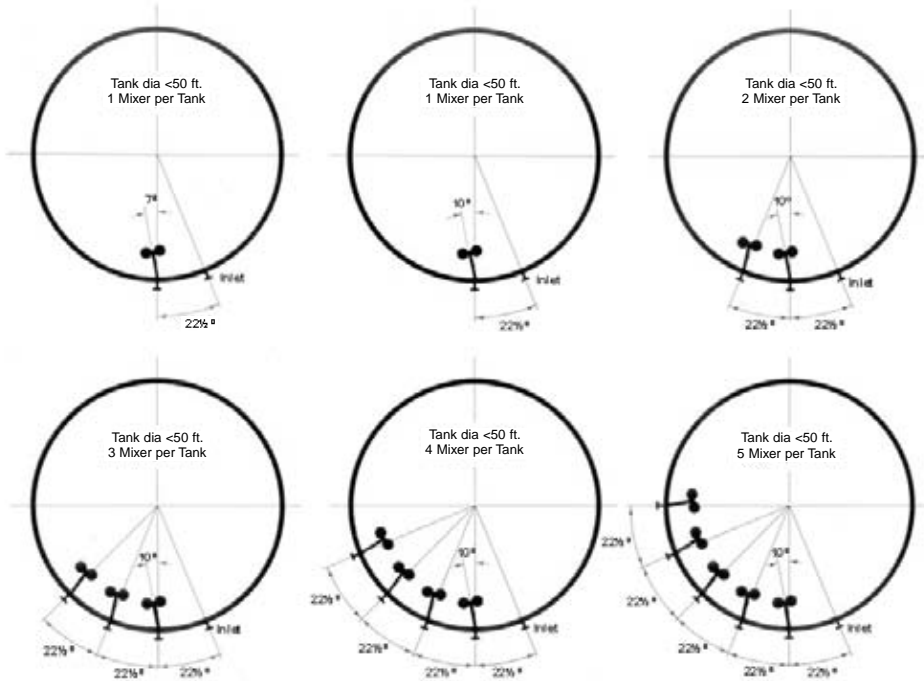

fig. 33

Recommended Mixer Orientations

Mixer Positioning: Fixed Angle Mixers



Plenty recommended mixer (Fixed Angle) positions for effective blending, homogeneity and temperature uniformity

Mixer Positioning: Swivel Angle Mixers

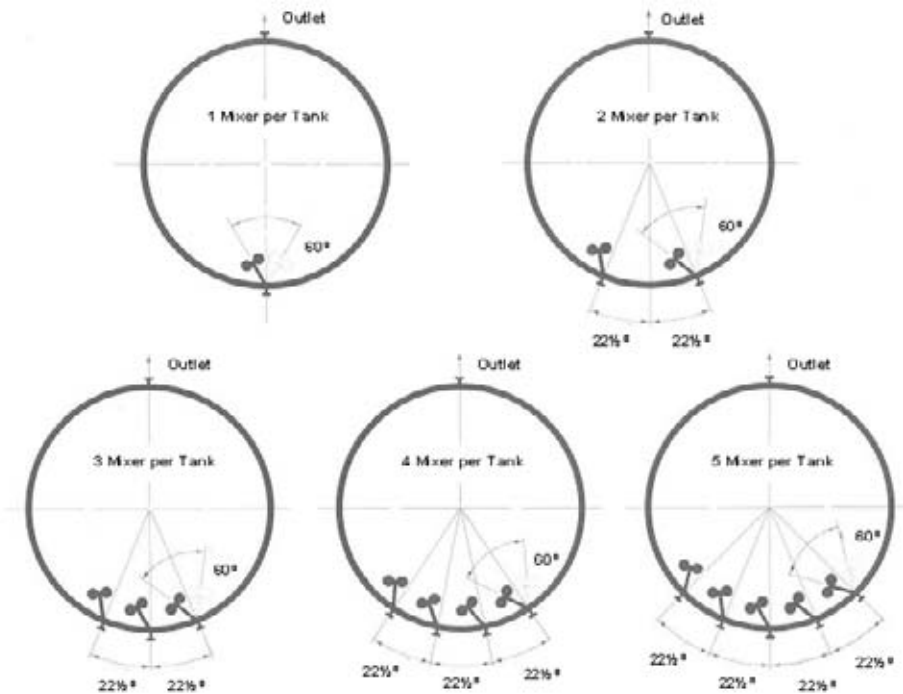

Plenty recommended mixer (Swivel Angle) positions for effective B.S. & W. control in crude oil tanks

Tank Mounting Details

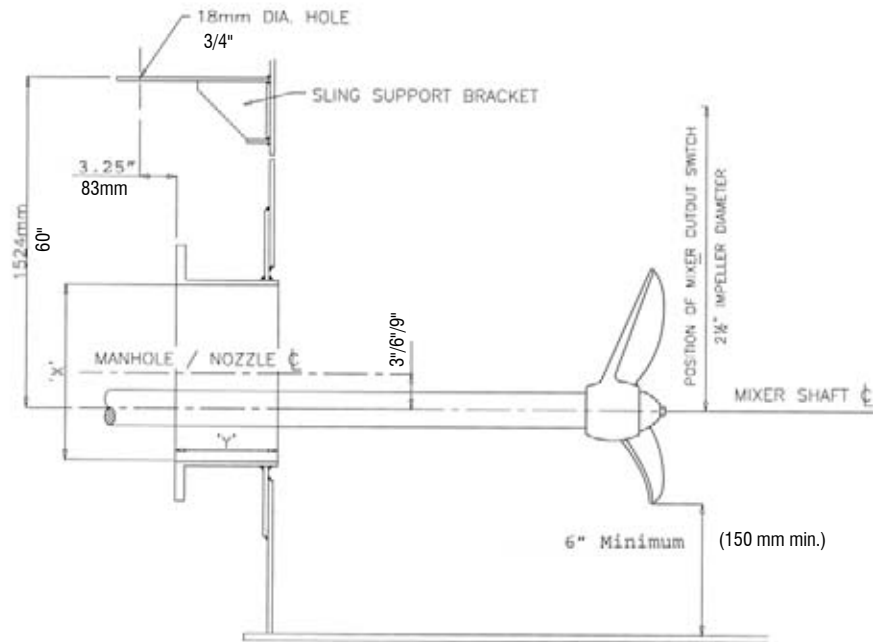

Manhole or Nozzle Size	Bore 'X' (in)	Nozzle length 'Y' (ins)									
		6	7	8	9	10	11	12	12 3/4	13 3/4	14 3/4
Maximum Impeller Diameter (in)											
18" ANSI 150	16.93	22	20	20	18	18	18	18	18	18	18
20" ANSI 150	18.9	26	24	22	20	20	20	20	20	20	20
20" API 650	20	28	24	24	24	22	22	22	22	22	20
24" ANSI 150	22.84	32	32	31	31	28	26	26	26	26	24
24" API 650	24	33	33	32	32	29	28	28	32	26	26
30" ANSI 150	28.35	33	33	33	33	33	32	32	32	32	32
30" API 650	30	33	33	33	33	33	33	33	33	33	33

Manhole or Nozzle Size	Bore 'X' (mm)	Nozzle length 'Y' (mm)									
		150	175	200	225	250	275	300	325	350	375
Maximum Impeller Diameter (mm)											
18" ANSI 150	430	560	510	510	460	460	460	460	460	460	460
20" ANSI 150	480	660	610	560	510	510	510	510	510	510	510
20" API 650	508	700	610	610	610	560	560	560	560	560	510
24" ANSI 150	580	815	815	790	790	700	660	660	660	660	610
24" API 650	610	840	840	815	815	740	700	700	660	660	660
30" ANSI 150	720	840	840	840	840	840	815	815	815	815	815
30" API 650	762	840	840	840	840	840	840	840	840	840	840

Process Operation Details

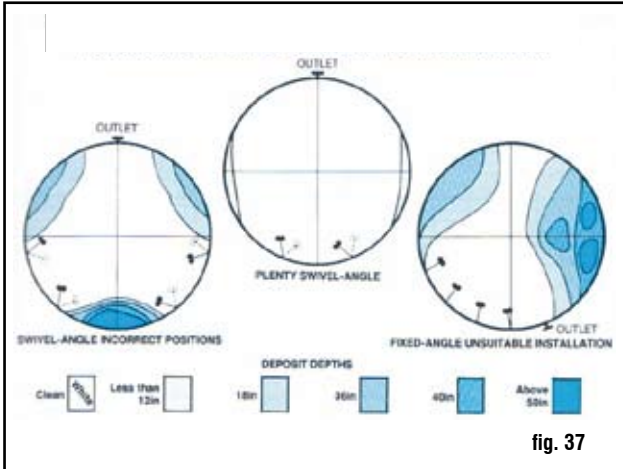

The results of correct mixer selection and positioning for B.S. & W. control in a 500,000 Bbls Crude Oil Tank

The Advantages of Operating Plenty Swivel Angle Mixers in Crude Oil Storage Tanks

In most crude oils there are varying quantities of Bottom Sludge and Water (BS&W) which contains paraffins, heavy ends, sediments of sand / silts and water. The rate of accumulation varies with the quality of the crude stored.

Some of the main reasons why BS&W should be controlled are:

- Tankage is always available for storage and not out of commission being cleaned or repaired
- Problems of sludge disposal are overcome.
- No environmental problems.
- Accumulation of BS&W can cause severe corrosion of tank floor and lower shell plates.
- Hazardous, dangerous and costly tank cleaning is practically eliminated.
- Large accumulations of BS&W can dramatically reduce 'operations' flexibility.
- Up to 70% of the BS&W is recoverable hydrocarbons which result in lost revenue if not utilized.
- Large accumulations, if not controlled or monitored, can result in floating roof damage when tank is on pump-down condition.
- If slugs of BS&W break free during pump-down then serious damage to the transfer pumps or even disruption of the refinery operation can result.
- Elimination of "plugged" water drains.

Operation

Swivel Angle Mixers

Normally used for suspension of sludge, solids etc., with occasionally a further requirement for blending (mixer set in 10° left position). For optimum mixing efficiency the mixers should be operated on the following swivel program.

Clean or New Tanks - Solids Suspension

30° left, 10° right, 20° left, 20° right, 10° left, 30° right, 30° left etc., angle changes being made every 2-3 months maximum. Specific process guidance is available from **Plenty** mixers.

Dirty Tanks - Solids Suspension

Program as for clean tanks but initially the mixer should operate for approximately 8 hours on one angle per batch i.e., first batch 30° left, second batch 10° right, and so on until such time that the deposits are reduced to a reasonable level. Then revert to a change of swivel angle every 2-3 months. Specific process guidance is available from **Plenty** mixers.

Blending, Maintaining Homogeneity, Temperature, Uniformity

The mixer should be positioned at the 10° left angle to ensure full top to bottom turnover.

Typical mixing action in a crude oil storage tank

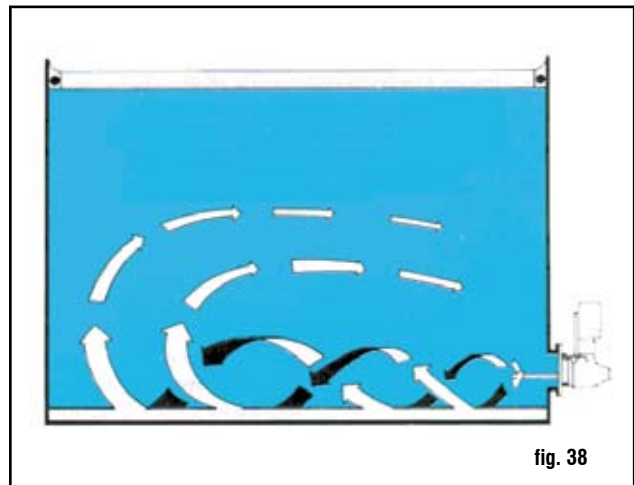

Mounting Flange Details

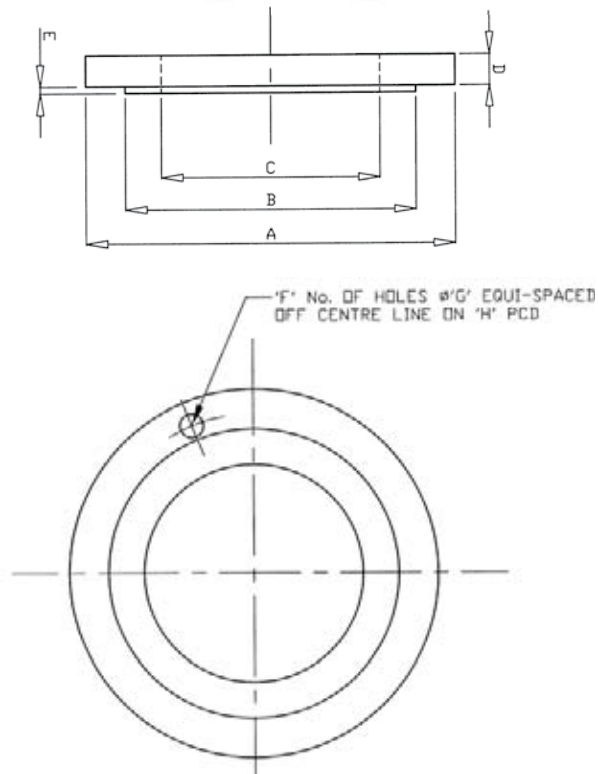

NOTES :

1. Dimensions in brackets are metric.
2. Mixers without manways are supplied with this flange studded.
3. Flange thickness does not conform to ANSI or API standards
4. Thickness of flange ,D' is 1.125" (28.6) on swivel angle models

STANDARD	A O/D	B R.F. DIA.	C N.B.	D THK	E RF. HT.	F NO HOLES	G HOLE DIA.	H PCD	REMARKS
8" ANSI 150 RF	13.5" (343)	10.63" (270)	8"	-	0.062" (1.5)	8	0.875" (22)	11.75" (298)	45MM & 60MM SEE NOTE 2.
10" ANSI 150 RF	16" (406)	12.75" (324)	10"	-	0.062" (1.5)	12	1" (25)	14.25" (362)	70MM & 85MM SEE NOTE 2.
20" ANSI 150 RF 20" API NOZZLE	27.5" (699)	23" (584)	20"	0.875" (22)	0.062" (1.5)	20	1.25" (32)	25" (635)	DIMN. ,D' NON STANDARD
24" ANSI 150 RF 24" API NOZZLE	32.75" (832)	27.25" (692)	24"	0.875" (22)	0.062" (1.5)	20	1.375" (35)	29.5" (749)	DIMN. ,A' & ,D' NON STANDARD
30" ANSI 150 RF 30" API NOZZLE	38.75" (984)	33.75" (857)	30"	0.875" (22)	0.062" (1.5)	28	1.375" (35)	36" (914)	DIMN. ,D' NON STANDARD
20" API 650 MANWAY	28.75" (730)	-	20"	0.875" (22)	-	28	0.875" (22)	26.25" (667)	DIMN. ,D' NON STANDARD
24" API 650 MANWAY	32.75" (832)	-	24"	0.875" (22)	-	28	0.875" (22)	30.25" (768)	DIMN. ,D' NON STANDARD
30" API 650 MANWAY	38.75" (984)	-	30"	0.875" (22)	-	42	0.875" (22)	36.25" (921)	DIMN. ,D' NON STANDARD
24" BS 2654 1956 & 1965 ALSO 24" SHELL T280058	31" (787)	-	24"	0.875" (22)	-	36	0.875" (22)	28.5" (724)	DIMN. ,D' NON STANDARD
600 BS 2654 1973	(780)	-	(600)	(22)	-	36	(23)	(740)	DIMN. ,D' NON STANDARD
600 BS 2654 1975	(780)	-	(600)	(22)	-	36	(22)	(725)	DIMN. ,D' NON STANDARD

Recommended Cut Out Dimensions of Floating Roof Tanks Fitted with Fixed Angle Mixers

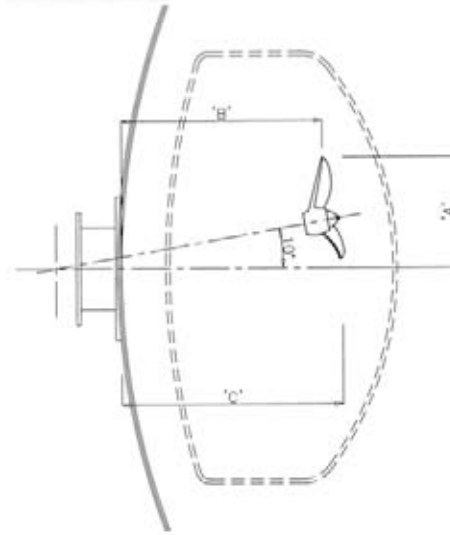
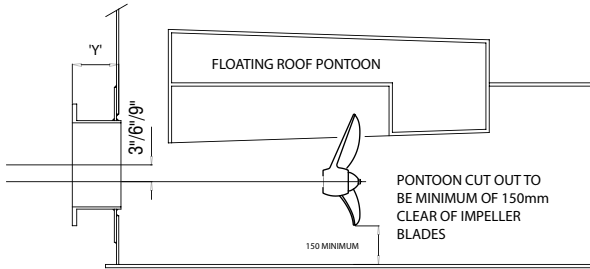

- 'A' = Max. offset of impeller swept arc from tank/nozzle center line.
- 'B' = Min. clearance (tank wall to back face of impeller)
- 'C' = Max. protrusion (tank wall to impeller tip).

Mixer Size	'A' (in)		Nozzle length 'Y' (ins)									
			6	7	8	9	10	11	12	12 3/4	13 3/4	14 3/4
			Position of Impeller relative to tank wall (in)									
45*	16 1/4	'B'	12 1/4	11 1/4	10 1/4	9 1/4	8 1/4	7 1/4	6 1/4	* manhole/nozzle too long		
45*	16 1/4	'C'	15 1/2	14 1/2	13 1/2	12 1/2	11 1/2	10 1/2	9 1/2			
60	18 1/2	'B'	17 1/2	16 1/2	15 1/2	14 1/2	13 1/2	12 1/2	11 1/2	10 1/2	9 1/2	8 1/2
60	18 1/2	'C'	21 1/2	20 1/2	19 1/2	18 1/2	17 1/2	16 1/2	14 1/2	14 1/4	13 1/2	12 1/2
70	23	'B'	26	25	24	23	22	21	20	19	18	17
70	23	'C'	31 1/4	30 1/4	29 1/4	28 1/4	27 1/4	27 1/4	25 1/4	24 1/4	23 1/4	22 1/4
85	24	'B'	27 1/2	26 1/2	25 1/2	24 1/2	23 1/2	23	21 1/2	20 1/2	19 1/2	18 1/2
85	24	'C'	34 1/4	33 1/4	32 1/4	31 1/4	30 1/4	29 1/4	28 1/4	27 1/4	27 1/4	25 1/4

Mixer Size	'A' (mm)		Nozzle length 'Y' (mm)									
			150	175	200	225	250	275	300	325	350	375
			Position of Impeller relative to tank wall (mm)									
45*	410	'B'	311	286	260	235	210	184	159	* manhole/nozzle too long		
45*	410	'C'	394	368	343	318	292	267	241			
60	470	'B'	445	419	394	368	345	318	292	267	241	216
60	470	'C'	546	521	495	470	445	419	368	364	343	317
70	580	'B'	660	635	610	584	559	533	508	483	457	432
70	580	'C'	794	768	743	718	692	667	641	616	591	565
85	610	'B'	699	673	648	622	597	572	546	521	495	470
85	610	'C'	870	844	819	794	768	743	718	692	667	641

Recommended Cut Out Dimensions of Floating Roof Tanks Fitted with Swivel Angle Mixers

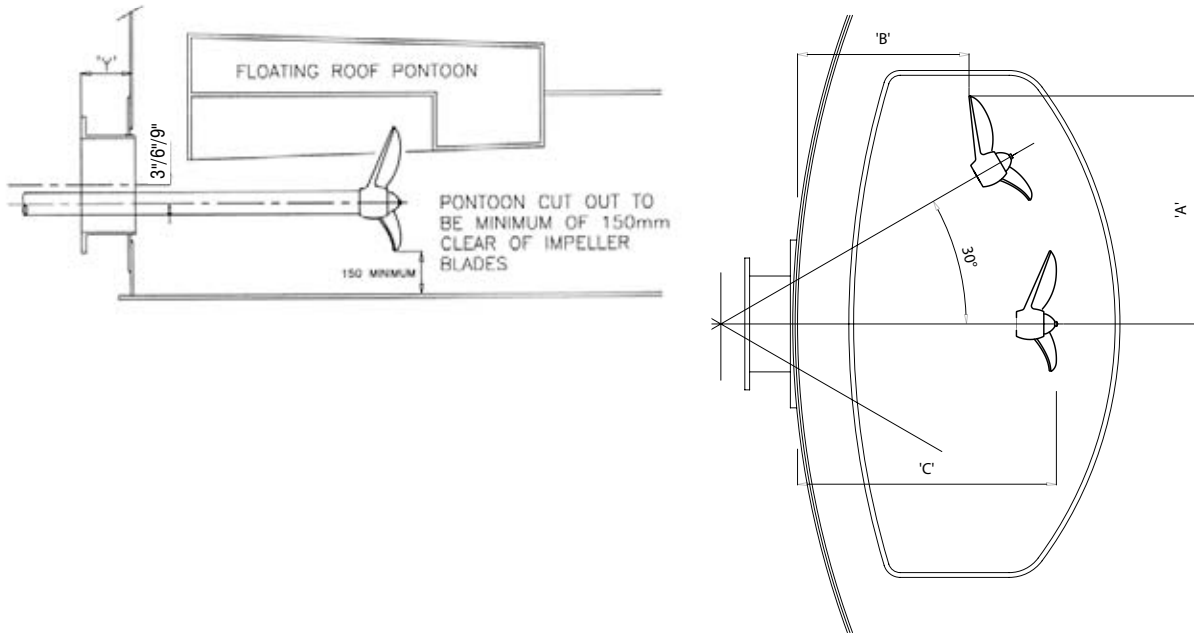

'A' = Max. offset of impeller swept arc from tank/nozzle center line.
 'B' = Min. clearance (tank wall to back face of impeller)
 'C' = Max. protrusion (tank wall to impeller tip).

Mixer Size	'A' (in)		Nozzle length 'Y' (ins)									
			6	7	8	9	10	11	12	12 3/4	13 3/4	14 3/4
			Position of Impeller relative to tank wall (in)									
60	584	'B'	7 1/2	6 1/2	5 1/2	manhole/nozzle too long						
60	584	'C'	20 1/2	19 1/2	18 1/2							
70	787	'B'	10 1/4	9 1/4	8 1/4	7 1/4	6 1/4	manhole/nozzle too long				
70	787	'C'	27 1/2	26 1/2	25 1/2	24 1/2	23 1/2					
85	813	'B'	11 3/4	10 3/4	9 3/4	8 3/4	7 3/4	6 3/4	5 3/4	manhole/nozzle too long		
85	813	'C'	30 3/4	29 3/4	28 3/4	27 3/4	26 3/4	25 3/4	24 3/4			

Mixer Size	'A' (mm)		Nozzle length 'Y' (mm)									
			150	175	200	225	250	275	300	325	350	375
			Position of Impeller relative to tank wall (mm)									
60	584	'B'	191	165	139	manhole/nozzle too long						
60	584	'C'	521	495	470							
70	787	'B'	260	235	210	184	159	manhole/nozzle too long				
70	787	'C'	699	673	648	622	597					
85	813	'B'	298	273	248	222	197	171	146	manhole/nozzle too long		
85	813	'C'	781	756	730	705	679	654	629			

Typical Site Reference

Plenty's experience and knowledge is based upon data accumulated over many years, and field tests conducted with Shell, ExxonMobil and BP refineries in the United Kingdom and Europe.



Plenty swivel angle belt drive mixers on a 1,000,000 Bbl (160,000 m³) crude oil tank in Europe.



Plenty swivel angle gear drive mixer in a Russian oil refinery



Installing a *Plenty* belt drive mixer in Europe



Final installation of a *Plenty* belt drive mixer



Plenty Mixer installed on a double skinned tank.



Plenty swivel angle gear drive mixer complete with automatic actuator

Selected References

Country	Qty	End Users
Asia, Far East, Australia		
Australia	90	Shell, Mobil, Caltex, BP
China	150	Chinese Petroleum Company, Dalian Refinery, Shanghai Yinfu Oils
India	500	Indian Oil Corporation, Reliance Petroleum, Kochi Refineries
Indonesia	30	Pertamina
Korea	350	LG Caltex Oil, Hyundai Oil, Ssangyong Oil, SK Corporation
Malaysia	230	Petronas, Shell, Esso, Malaysian Refining Company
Pakistan	40	Attock Refinery, National Refinery, Pakistan Oilfields
Philippines	100	Shell, Caltex, Petron
Singapore	450	Shell, ExxonMobil, Caltex, Singapore Refining Co, Vopak, Singapore Petroleum Co.
Thailand	300	Thai Oil, Allied Refining Co, Bangchak Petroleum, Thai Petrochemical Industries
Taiwan	30	Chinese Petroleum Corporation, Formosa Petrochemicals
Americas		
Argentina	60	Shell, Terminal 6 S.A., Bolland, YPF
Colombia	80	Ecopetrol, Oxy
Chile	10	Refineria De Petroleo Concon, ENAP
Ecuador	90	Amazonas & Balao Terminals, Esmeraldas Refinery
Venezuela	60	PdVSA, Shell
USA/Canada	1000	Shell, Exxon, Amoco, Chevron, Conoco, Marathon Oil, Total, Plains Valero, Sunoco, Kinder Morgan
Europe		
Belgium	30	Esso, Fina
Croatia	60	Rafinerija Nafta Sisak, Rafinerija Rijeka, Janaf
Czech Republic	50	Ceska Refinery, Slovnaft
Denmark	20	Statoil, Dansk Shell
France	130	Total Fina Elf, BP, Shell, Exxon
Germany	50	Shell, Esso, Holborn Europa
Greece	25	Hellenic Petroleum, Petrola Hellas SA
Hungary	15	MOL, Magyar Olaj
Italy	25	Raffineria Di Roma, Agip Petroli, ERG
Latvia	30	Ventspils Nafta
Netherlands	165	Shell, Esso, Total, MOT, MET, Paktank, Vopak, Team Terminal, Nerefco
Poland	25	Raffineria Gdansk, Peru Przyjazan
Spain	150	Repsol, CEPSA, BP, Petronos, Lubrisur, Forestal del Atlantico
Sweden	50	Nynas, Shell Skandinaviska Raff, Preem
Turkey	80	Tupras, Mobil
UK	580	Shell, BP, ExxonMobil, Texaco, Phillips, Talisman, Petroplus
Slovakia	5	Budkovice
Slovenia	10	Nafta Lendava
Middle East, Africa		
Bahrain	35	Bahrain Petrochemical Company
Egypt	200	NASR Petroleum Company, Alexandria Petroleum Company, Sumed
Iran	280	National Iranian Oil Company
Kuwait	25	Kuwait National Petroleum Company, Kuwait Oil Company
Libya	60	Jawaby Oil
Qatar	40	QP
Saudi Arabia	60	Aramco
South Africa	25	Caltex, Shell
United Arab Emirates	130	ADNOC, ZADCO, ENOC

Notes

Notes

Plenty, Rochester:
135 Mt. Read Blvd.
Rochester, NY 14611 USA
Phone: (585) 436-5550
Fax: (585) 436-5589

Plenty, Macclesfield:
1st Floor, Clark House
Hulley Road, Macclesfield
Cheshire, SK10 2LU UK
Phone: +44 (0) 1625 505770
Fax: +44 (0) 1625 668980

Global Headquarters: SPX Process Equipment, Delavan, WI USA



SPX[®]
PROCESS EQUIPMENT

Your local contact:



SPX Process Equipment
135 Mt. Read Blvd.
Rochester, NY 14611
Phone: (585) 436-5550 Fax: (585) 438-5589
E-mail: mixers.plenty@spx.com

For more information about our worldwide locations, approvals, certifications, and local representatives, please visit www.spxpe.com.

SPX reserves the right to incorporate our latest design and material changes without notice or obligation. Design features, materials of construction and dimensional data, as described in this bulletin, are provided for your information only and should not be relied upon unless confirmed in writing. Certified drawings are available upon request.